



**WS Technologies Inc.**

# **Beacon Test Bench**

**Operator's Manual**

**STB100**

**Version 2.30**

Information contained in this manual is subject to change without notice. Please consult the website at [www.wst.ca](http://www.wst.ca) for new Operator's Manual updates. Complying with all applicable copyright laws is the responsibility of the user. Without limiting the rights under copyright, no part of this document may be reproduced, stored in a retrieval system, or transmitted in any form or by any means including but not limited to, electronic, mechanical, photocopying, recording, or otherwise, or for any purpose, without the written permission of WS Technologies Inc. (WST). WST may have patents, patent applications, trademarks, copyrights, or other intellectual property rights covering subject matter in this document. Except as expressly provided in any written license agreement from WST, the furnishing of this document does not give you any license to these patents, trademarks, copyrights, or other intellectual property.

The purchaser shall not, in any event, be entitled to, and WST shall not be liable for indirect, special, incidental or consequential damages of any nature including, without limitation, business interruption costs, loss of profit or revenue, loss of data, promotional or manufacturing expenses, overhead, injury to reputation or loss of customers, even if WST has been advised of the possibility of such damages. In any event, purchaser's recovery from WST for any claim shall not exceed purchaser's purchase price for the product giving rise to such claim irrespective of the nature of the claim, whether in contract, tort, warranty, or otherwise. WST shall not be liable for and purchaser shall indemnify, defend and hold WST, its agents, distributors, dealers, successors and assigns harmless from any and all claims, damages or losses, including injury or death, arising from or relating to the use or failure of the products.

**Copyright © WS Technologies Inc.  
All rights reserved.**

**Printed in Canada  
March 2026**

# CONTENTS

INTRODUCTION .....	1
SUMMARY OF MODELS AND OPTIONS .....	1
UNPACKING .....	1
GETTING STARTED .....	2
Front Panel: .....	2
Rear Panel: .....	2
Installing the Application: .....	3
Launching the Application: .....	4
Application Screens: .....	4
Measurement Screen: .....	5
Setup Screen: .....	5
Limits Screen: .....	6
User IO Screen: .....	7
Device Status Panel: .....	8
Beacon Setup Screen Configuration: .....	8
User Data section: .....	8
Device Settings: .....	8
10MHz Reference Setting: .....	8
Input Mode Settings: .....	9
Direct Input mode: .....	9
Antenna mode: .....	9
Screen Box mode: .....	9
Files: .....	9
Report Header Logo: .....	9
Software Updates and Upgrades: .....	10
Misc: .....	10
Measurement Detected Sound: .....	10
VHF Training Frequencies: .....	10
Measurements: .....	10
Select Channels for Measurement: .....	10
Test Duration: .....	10
Cable Loss Factors: .....	11
Location Format: .....	11
Location: .....	11
VIT Settings: .....	11
Limit Tester Configuration: .....	11
Selecting Parameters: .....	11
Setting Lower and Upper Limits: .....	12
Limits Files: .....	12
Selecting and Sorting Limits: .....	12
Miscellaneous Limits Conditions: .....	12
Stop Measurement When Fail: .....	12
Fail if Location is Default: .....	12
Measurement Screen Configuration: .....	13
Measure: .....	13
Screen View: .....	14
File: .....	15

Test Report:.....	16
VIT Configuration:.....	16
Zero Current Sensor:.....	16
VIT Measurements - General: .....	17
Voltage and Current Measurements:.....	17
Voltage: .....	17
Current – DC Overload Condition:.....	17
Temperature: .....	18
GPS Receiver:.....	18
<b>MAKING MEASUREMENTS</b> .....	<b>19</b>
Connecting the Beacon: .....	19
Direct Connection: .....	19
Antenna: .....	19
Screen Box Connection: .....	20
Single Mode Measurement:.....	20
Continuous Mode Measurement:.....	21
Leakage Measurement:.....	22
<b>MEASUREMENT RESULTS</b> .....	<b>23</b>
Results Screen: .....	23
<b>TEST REPORTS AND DATA FILES</b> .....	<b>24</b>
Generate and Print Test Report:.....	24
Data Files: .....	24
Main Measurement Data File Structure: .....	25
First Generation Beacon (FGB) File Structure:.....	25
Second Generation Beacon (SGB) File Structure: .....	25
AIS Measurement Data File Structure: .....	26
VIT Data File Structure: .....	26
Graphics Files:.....	26
<b>USER I/O SCREEN</b> .....	<b>27</b>
Breakout Board and Cable: .....	27
<b>AIS TRANSCEIVER MEASUREMENTS</b> .....	<b>28</b>
General:.....	28
Application Screens:.....	28
IMO Test screen:.....	29
Individual Tests screen:.....	29
Setup screen: .....	30
Device Status Panel: .....	30
IMO Test Configuration:.....	31
Transceiver:.....	31
Start New Test:.....	32
Report:.....	33
Device Status Panel: .....	34
Main IMO Test Screen:.....	34
Transceiver:.....	34
Test History: .....	35
Test Details:.....	35
Individual Tests Screen Configuration: .....	35
Transceiver:.....	36

Pilot Plug: .....	36
AIS Tx Channel: .....	36
RF Input Mode: .....	36
Main Individual Test Screen: .....	37
Tests: .....	37
Results: .....	38
Activity Log: .....	38
Setup Screen Configuration: .....	38
Radio Inspector Data: .....	39
Device Settings: .....	39
Files: .....	39
Pilot Plug: .....	39
Report Header Logo: .....	40
IMO Test: .....	40
Individual Tests: .....	40
MAKING AIS MEASUREMENTS .....	41
Auto Testing: .....	41
Manual Testing: .....	41
1. Installation Details: .....	41
2. AIS Programming – Static Information: .....	42
3. AIS Programming – Dynamic Information: .....	43
4. AIS Programming – Voyage Related Information: .....	44
5. Performance Test: .....	45
6. "On Air" Performance Test: .....	46
Review: .....	47
IMO TEST REPORTS AND DATA FILES .....	48
Generate and Print IMO Test Report: .....	48
Data Files and Folder Structure: .....	48
Measurement Table Schema: .....	49
SOFTWARE UPDATES .....	49
STB100 MODEL UPGRADING .....	49
FREQUENTLY ASKED QUESTIONS .....	50
SPECIFICATIONS .....	53
REGULATORY INFORMATION .....	56
DECLARATION OF CONFORMITY .....	57
WARRANTY INFORMATION .....	58
CALIBRATION .....	58
RETURNS .....	58
POWER CONVERSION CHART - dBm to Watts .....	59

**WARNING!**

**DO NOT ACTIVATE ANY BEACON IN ITS NORMAL ACTIVATE MODE UNLESS THE BEACON IS IN A SCREEN BOX (TSE100B) OR A SCREEN ROOM. DOING SO COULD RESULT IN A FALSE DISTRESS ALERT.**

**WARNING!**

**WHEN USING DIRECT CONNECTION INPUT MODE DO NOT EXCEED A BURST POWER LEVEL OF 20 WATTS OR A CONTINUOUS POWER LEVEL OF 2 WATTS. DAMAGE WILL RESULT!**

## INTRODUCTION

Thank you for choosing the STB100 Beacon Test Bench.  
This Operator's Manual explains the operation of this equipment.

## SUMMARY OF MODELS AND OPTIONS

**STB100:** This is the base model. It measures and decodes all First Generation (FGB) Cospas-Sarsat EPIRBs, PLBs, and ELTs. It decodes the 406 MHz message, measures the 406 MHz transmitter, the 121.5 MHz transmitter, and the 243 MHz transmitter. It also measures voltage and current supplied to a beacon, along with the leakage current when a beacon is switched to standby mode. Accessory items include up to 2 temperature probes and a breakout board kit for measuring various USER I/O functions.

**API Set option:** The API Set option is available for those that wish to customize their software program.

**AIS(Rx):** Adds the capability to decode and measure the AIS channel in AIS-EPIRBs.

**AIS(Rx & Tx):** Adds the capability to measure AIS transceivers in accordance with IMO MSC.1Circ.1252. This option will measure AIS-EPIRBs also.

**Second Generation Beacon (SGB) option:** Adds the capability of measuring Second Generation Beacons.

## UNPACKING

Please verify the contents of your package. It should contain:

- STB100 Beacon Test Bench
- Custom Waterproof Hardcase w/ Strap
- Operator's Manual
- Certificate of Calibration with Calibration Data
- Front Panel Antenna
- USB to PC Interface Cable
- GPS Magnetic Mount Active Antenna
- AC power cable

### NOTICE!

Install the Beacon Test Bench software before  
connecting the device to the USB port.

# GETTING STARTED

Please read this Operator's Manual to become familiar with the operation of the Beacon Test Bench.

## Front Panel:

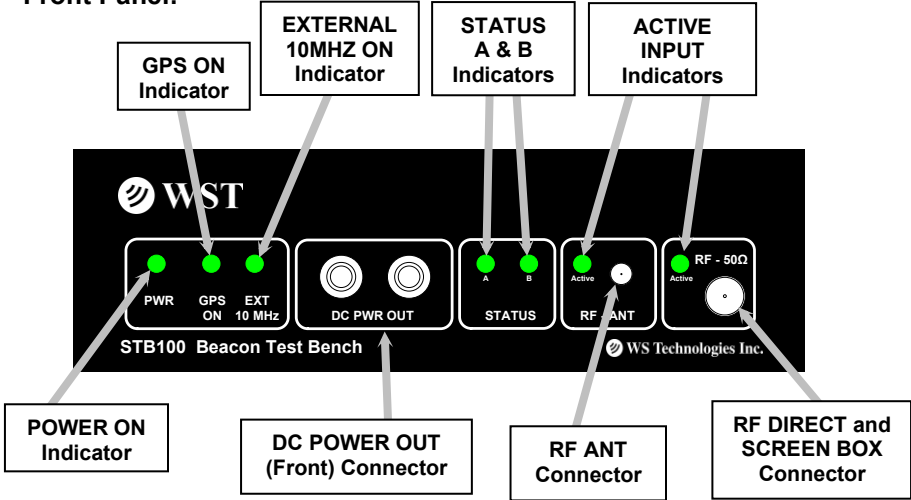

## Rear Panel:

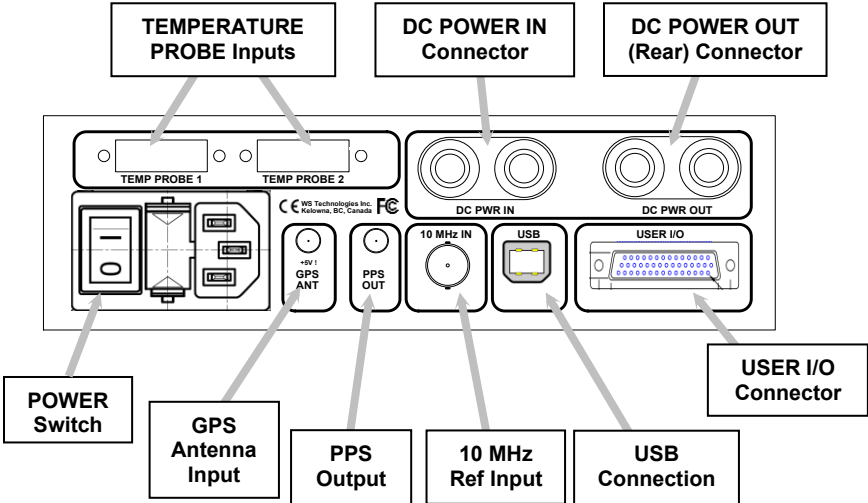

## Installing the Application:

**NOTICE!**  
Install the Beacon Test Bench software before connecting the device to the USB port.

The STB100 Application must be installed on your computer prior to connecting the device.

Go to [www.wst.ca/stb100](http://www.wst.ca/stb100) and install the latest version of the STB100 software. The following message may appear.

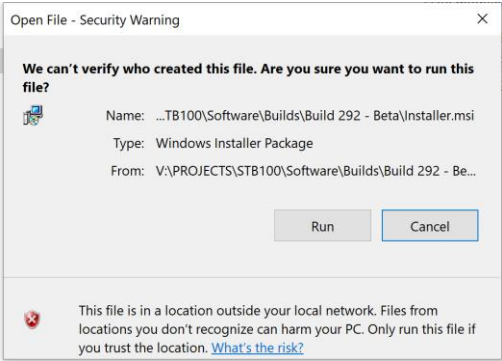

Click **Run** to install the application on the computer.

The STB Test Bench Wizard will appear.

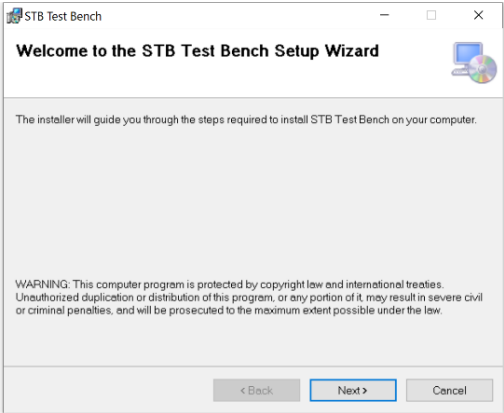

Follow the prompts to complete the installation.

The STB100 icon will appear on your desktop.

**Launching the Application:**

Click the desktop icon to launch the STB100 application. A splash screen will appear, followed by the **Measurement** screen.

**Application Screens:**

The application has four main screens, the **Measurement** screen, the **Setup** screen, the **Limits** screen, and the **USER I/O** screen, each accessible from the tabs near the top of the screen.

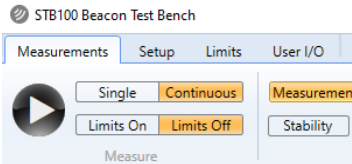

If the STB100 includes the AIS(Rx&Tx) option, the following screen will appear:



# Measurement Screen:

**STB100 Beacon Test Bench**

Measurements Setup Limits User I/O

Single Continuous Measurement - Basic Detailed RF Measurements AIS Details

Filename: burst-35

Generate

Limits On Limits Off Stability VIT Leakage Graphics File View

Open Measurement File: Browse

File Test Report

---

**Device Status**  
Not Connected

MODEL: -----  
S/N: -----  
CAL DUE DATE: -----  
-----

FW REV: -----  
DRIVER REV: 2.15  
SW REV: 2.15.290b

INT TEMP: ----- °C

**Settings Status**  
10MHz Int  
RF IN: Direct

**Measurement Mode**  
Continuous  
Limit Tester: Off

**Channels Selected**  
406MHz  
121.5MHz  
243MHz

---

**15 Hex ID: -----**

Protocol: -----  
Full Hex: -----  
Burst Mode: -----  
Date/Time: -----

**RF Measurements**

406MHz	121.5MHz	243MHz
Frequency (Int): -----	Frequency (Int): -----	Frequency (Int): -----
Power: -----	Peak Power: -----	Peak Power: -----
Power Rise Time: -----	Sweep Direction: -----	Sweep Direction: -----
Pre-Burst Level: -----	Audio Frequency Upper: -----	Audio Frequency Upper: -----
Repetition Period: -----	Audio Frequency Lower: -----	Audio Frequency Lower: -----
Bit Rate: -----	Audio Sweep Range: -----	Audio Sweep Range: -----
Unmodulated CW: -----	Sweep Rep Rate: -----	Sweep Rep Rate: -----
Transmission Time: -----	Modulation Index: -----	Modulation Index: -----
Modulation Rise Time: -----	Duty Cycle: -----	Duty Cycle: -----
Modulation Fall Time: -----		
Positive Phase: -----		
Negative Phase: -----		
Modulation Symmetry: -----		

**Graphics**

**Details**

**Leakage**

Measure Leakage

Leakage Current: -----

---

**File View**

- burst-34 (3)
- burst-33
- burst-32
- burst-31
- burst-30 (32)
- burst-29
- burst-26
- burst-23
- burst-21
- burst-20 (15)
- burst-19
- burst-18
- burst-17
- burst-16
- burst-15
- burst-14
- burst-13
- burst-12
- burst-11 (2)
- burst-9
- burst-8
- burst-7
- burst-6
- yolo-39
- yolo-38
- yolo-37
- yolo-36

# Setup Screen:

**STB100 Beacon Test Bench**

Beacon AIS

Measurements Setup Limits User I/O IMD Test Individual Tests Setup

---

**Device Status**  
Connected

MODEL: STB100-121  
S/N: 60003  
CAL DUE DATE:  
2023-11-25

FW REV: 0003.0074  
DRIVER REV: 2.16  
SW REV: 2.16.292b

INT TEMP: 28.7 °C

**Settings Status**  
10MHz Int  
RF IN: Direct

**Measurement Mode**  
Continuous  
Limit Tester: Off

**Channels Selected**  
406MHz  
121.5MHz  
243MHz

---

**User Data**

Name:

Company:

**Device Settings**

10MHz

RF IN Mode

Internal  
 External  
 Direct  
 Antenna  
 Screen Box

**Files**

Measurement Files Location C:\WST\STB100

Filename:   Auto Increment Filename

**Report Header Logo**

Enable Image in Test Report

**Upgrades and Software Updates**

Current Version: 2.16.292b

**Misc**

Measurement Detected Sound  On  Off

VHF Training Frequencies

121MHz	Off
243MHz	Off

---

**Measurements**

Select Channels for Measurement

406MHz  
 121.5MHz  
 243MHz  
 AIS

**Test Duration**

Test duration in continuous mode:  (1 to 43200 minutes)

**Cable Loss Factors**

<input type="checkbox"/> 406 MHz	<input type="text" value="0.0"/> dB
<input type="checkbox"/> 121.5 MHz	<input type="text" value="0.0"/> dB
<input type="checkbox"/> 243 MHz	<input type="text" value="0.0"/> dB
<input type="checkbox"/> AIS	<input type="text" value="0.0"/> dB

**Location Format**

dd.ddddd°  
 d°d' mm.mm"

**Location**

GPS on   
 GPS off

Location of STB100 installation (dd.ddddd°)

Latitude:   
Longitude:

**VIT Settings**

VIT functions on  VIT - real time:

Voltage In: -----  
Voltage Out: -----  
Current: -----  
Temperature 1: -----  
Temperature 2: -----

Ensure all loads are removed and then press the button to zero the current sensor.

# Limits Screen:

STB100 Beacon Test Bench



Measurements Setup **Limits** User I/O

Limits Filename:       Stop measurement when FAIL

Open limit tester file:   Fail if location is default

File Select Options

SELECT	PARAMETER	UNITS	LOWER LIMIT	UPPER LIMIT
<input checked="" type="checkbox"/>	406 Frequency (Int Ref)	MHz	406.019575	406.081425
<input checked="" type="checkbox"/>	406 Frequency (Ext Ref)	MHz	406.019999	406.081001
<input checked="" type="checkbox"/>	406 Power (Direct)	dBm	34.5	39.5
<input checked="" type="checkbox"/>	406 Power (Direct) (ELT-DT)	dBm	35.5	39.5
<input type="checkbox"/>	406 Power (Antenna)	%	5.0	110.0
<input type="checkbox"/>	406 Power (Scn Box)	%	5.0	110.0
<input type="checkbox"/>	406 Power Rise Time	ms	0.00	5.50
<input type="checkbox"/>	406 Pre-Burst Level	dBm	-50.0	-11.0
<input type="checkbox"/>	406 Rep Period	s	47.5	52.5
<input type="checkbox"/>	406 Rep Period (ELT-DT)	s	5.0	30.0
<input type="checkbox"/>	406 Bit Rate	Hz	395.8	404.2
<input type="checkbox"/>	406 Bit Rate (ELT-DT)	Hz	399.4	400.6
<input type="checkbox"/>	406 Unmodulated CW Time	ms	157.6	162.4
<input type="checkbox"/>	406 Total Transmission Time (Short)	ms	435.1	444.9
<input type="checkbox"/>	406 Total Transmission Time (Long)	ms	514.3	525.7
<input type="checkbox"/>	406 Mod Rise Time	µs	40.0	260.0
<input type="checkbox"/>	406 Mod Rise Time (ELT-DT)	µs	40.0	170.0
<input type="checkbox"/>	406 Mod Fall Time	µs	40.0	260.0
<input type="checkbox"/>	406 Mod Rise Time (ELT-DT)	µs	40.0	170.0
<input type="checkbox"/>	406 Positive Phase	rad	0.96	1.24
<input type="checkbox"/>	406 Negative Phase	rad	-1.24	-0.96
<input type="checkbox"/>	406 Phase Symmetry	%	0.00	0.50
<input type="checkbox"/>	406 Short Term	/100ms	0.000e00	2.000e-09
<input type="checkbox"/>	406 Medium Term - Slope	/min	-1.000e-09	1.000e-09
<input type="checkbox"/>	406 Medium Term - Residual		0.000e00	3.000e-09
<input type="checkbox"/>	406 Nominal Frequency	MHz	406.019575	406.019575
<input type="checkbox"/>	406 Δ Distance (SLP, NLP, ELT-DT and RLS)	m	0	500
<input type="checkbox"/>	406 Δ Distance (JLP)	m	0	5250
<input type="checkbox"/>	406 Spectral Mask	dBc		
	Corner 1 (3kHz)			-17
	Corner 2 (7kHz)			-27
	Corner 3 (12 kHz)			-32
	Corner 4 (24 kHz)			-37

**Device Status**  
Not Connected

MODEL: -----  
S/N: -----  
CAL DUE DATE: -----  
-----

FW REV: -----  
DRIVER REV: 2.15  
SW REV: 2.15.290b

INT TEMP: ----- °C

**Settings Status**  
10MHz: Int  
RF IN: Direct

**Measurement Mode**  
Continuous  
Limit Tester: Off

**Channels Selected**  
406MHz  
121.5MHz  
243MHz

# User IO Screen:

STB100 Beacon Test Bench

— □ ×

Measurements Setup Limits User I/O

## Device Status

Connected   
MODEL: STB100-100  
S/N: 60001  
CAL DUE DATE:  
2022-12-14

FW REV: 0003.0067  
DRIVER REV: 2.15  
SW REV: 2.15.290b

INT TEMP: 28.4 °C

## Settings Status

10MHz: Int  
RF IN: Direct

## Measurement Mode

Continuous  
Limit Tester: Off

## Channels Selected

406MHz  
121.5MHz  
243MHz

## Relay Controls

Relay 1

Relay 2

## Auxiliary ADC

AuxADC 0  0.000 V

AuxADC 1  0.000 V

AuxADC 2  0.000 V

AuxADC 3  0.000 V

AuxADC 4  0.000 V

AuxADC 5  0.000 V

AuxADC 6  0.000 V

AuxADC 7  0.000 V

## Auxiliary IO

	Output		Input	
AuxIO 0	<input type="button" value="Set"/>	<input type="button" value="Clr"/>	<input type="button" value="Get"/>	Lo
AuxIO 1	<input type="button" value="Set"/>	<input type="button" value="Clr"/>	<input type="button" value="Get"/>	Lo
AuxIO 2	<input type="button" value="Set"/>	<input type="button" value="Clr"/>	<input type="button" value="Get"/>	Lo
AuxIO 3	<input type="button" value="Set"/>	<input type="button" value="Clr"/>	<input type="button" value="Get"/>	Lo
AuxIO 4	<input type="button" value="Set"/>	<input type="button" value="Clr"/>	<input type="button" value="Get"/>	Lo
AuxIO 5	<input type="button" value="Set"/>	<input type="button" value="Clr"/>	<input type="button" value="Get"/>	Lo
AuxIO 6	<input type="button" value="Set"/>	<input type="button" value="Clr"/>	<input type="button" value="Get"/>	Lo
AuxIO 7	<input type="button" value="Set"/>	<input type="button" value="Clr"/>	<input type="button" value="Get"/>	Lo

## Device Status Panel:

The Device Status Panel is shown on the left side which shows the user various device settings and the status of various functions.

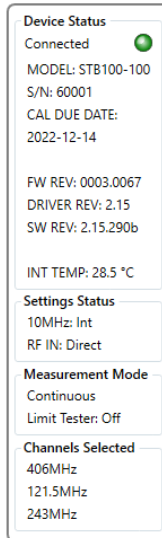

## Beacon Setup Screen Configuration:

Go to the **Setup Screen** by clicking on the **Setup tab**.

The **Setup Screen** has the following sections: User Data; Device Settings; Files; Report Header Logo; Upgrades and Software Updates; Misc; and Measurements.

### User Data section:

Enter the **Name** of the user performing the tests. Enter the name of the **Company**. This data will appear in the saved data files and on the Test Reports.

### Device Settings:

#### *10MHz Reference Setting:*

Select the desired **Internal** or **External** 10 MHz reference. The external 10 MHz must have a stability better than 10E-10.

### *Input Mode Settings:*

Select the desired RF Input mode: **Direct**, **Antenna**, or **Screen Box**.

### *Direct Input mode:*

Use this mode when connecting directly the output of the beacon using a 50Ω cable. This mode will result in a very accurate absolute power measurement in dBm.

#### **WARNING**

**DO NOT ACTIVATE ANY BEACON IN ITS NORMAL ACTIVATE MODE UNLESS THE BEACON IS IN A SCREEN BOX (TSE100B) OR A SCREEN ROOM. DOING SO COULD RESULT IN A FALSE DISTRESS ALERT.**

### *Antenna mode:*

This mode receives signals via the antenna attached to the front of the STB100. Use this mode when the beacon is transmitting its signal through its antenna.

The resulting power measurement units are relative and are shown in %.

### *Screen Box mode:*

Use this mode when the transmitting beacon is located in a Screen Box. The resulting power measurement units are relative and are shown in %.

### **Files:**

Click **Browse** to enter the desired location where all beacon measurement files will be located.

Enter the desired filename in the **Filename** box. When **Auto Increment Filename** is selected, the filename will be appended with a number. This number will automatically increment with each measurement. You can start the auto-incrementing number at any desired number by placing '-#' at the end of the filename. The # is the start number.

### **Report Header Logo:**

Click **Update Image** to select an image to be displayed at the top of a beacon test report. This image will be sized automatically to fit at the top of the Test Report.

To enable or disable displaying the selected image in a beacon Test Report, toggle **Enable Image In Test Report**.

### **Software Updates and Upgrades:**

Click **Upgrades** to enter an upgrade code if you have purchased an upgrade.

Click **Check for Updates** to see if Software Updates are available.

### **Misc:**

#### *Measurement Detected Sound:*

Select On or Off to enable or disable the audio sounds played when a signal is detected.

#### *VHF Training Frequencies:*

If the beacon you are testing has VHF training frequencies, you will need to activate and select the VHF Training Frequencies in order to measure. Click the **VHF Training Frequencies** dropdown to select the appropriate frequencies.

### **Measurements:**

The Measurements section of the Setup page has the following sections: Select Channels for Measurement; Test Duration; Cable Loss Factors; Location Format; Location; and VIT Settings.

#### *Select Channels for Measurement:*

Select the channels you wish to receive. The 243MHz and AIS channels cannot be selected at the same time.

**Note:** The AIS channel is available with the AIS(Rx) or AIS(Rx&Tx) upgrade.

#### *Test Duration:*

Select the box and enter the desired duration of the test in minutes. Testing will continue for the specified duration when in Continuous mode. If not selected, the test will run until Stop is pressed.

### *Cable Loss Factors:*

Enter the appropriate cable loss factors. These factors will be included in the power level measurements in Direct Input mode.

### *Location Format:*

Select the desired location format.

### *Location:*

The location of the STB100 installation can be entered manually or automatically. To enter automatically, select **GPS On**. Ensure the GPS antenna is connected to the **GPS ANT** connector on the rear of the STB100. Once the internal GPS receiver has location data, the green **GPS ON** LED on the faceplate will illuminate. Press **Get GPS Location** and the location will be entered into the Latitude and Longitude boxes. This information is used to provide a delta distance when location information is included in location protocol measurements.

### *VIT Settings:*

If VIT (Voltage, Current, and Temperature) measurements are desired, then the **VIT Functions On** box must be selected.

Once turned On, the VIT information will continually update in real-time directly on the Setup screen.

### **Limit Tester Configuration:**

Go to the **Limits** screen by clicking on the **Limits tab**.

**Note:** Limits can be turned ON or OFF in the Measurement section in the ribbon on the main **Measurement screen**.

### **Selecting Parameters:**

You can select which parameters you wish to include in the Limits Testing. When a parameter is selected, that parameter will be compared to the Lower and Upper Limits and a Pass or Fail indication will result.

## Setting Lower and Upper Limits:

The Upper and Lower Limits can be changed if desired. Click in the cell you wish to change and enter the desired value. If you wish to restore the default values, click on the **Load Defaults** button in the **File** section of the ribbon on the **Setup** screen.

## Limits Files:

You can save various Limits profiles by clicking **Save**. To recall a Limits file, click **Browse** and select the desired File. The current measurement will always be compared to the Limits currently loaded.

## Selecting and Sorting Limits:

The **Select All**, **Deselect All** and **Select Defaults** buttons allow you easily modify selected limits. Clicking the **PARAMETER** and **SELECT** tabs will allow you to order the limits by name and selected.

## Miscellaneous Limits Conditions:

### *Stop Measurement When Fail:*

When this is selected, and you are in Continuous mode, the measurements will stop once a Fail is encountered.

### *Fail if Location is Default:*

If this is selected, a Fail will result if the decoded location is the default condition (\*\*. \*\*).

## Measurement Screen Configuration:

The ribbon in the **Measurements** screen has the following sections: Measure; Screen View; File; and Test Report.

### Measure:

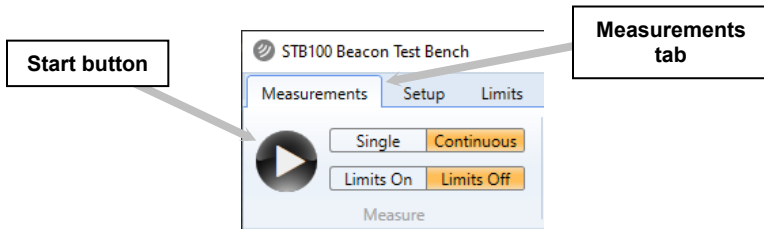

The **Start** button will start the test. The test will continue until the **Stop** button is pressed or the test duration (set in the Setup section) is reached.

**Single** or **Continuous**. In Single mode, only one measurement is taken. In Continuous mode, measurements will continue for the duration of the test (set in Setup), or until **Stop** is pressed.

**Limits On** or **Limits Off**. Select Limits On if you wish to compare the parameters selected in the **Setup** section to minimum and maximum values.

## Screen View:

You can select which sections to view by toggling On/Off the buttons in the **Screen View** section of the ribbon. When Off, that section will be hidden.

The screenshot displays the STB100 Beacon Test Bench software interface. The main window is titled "Measurements" and contains several sections:

- Device Status:** Connected, MODEL: STB100-100, S/N: 60001, CAL DUE DATE: 2022-12-14, FW REV: 0003.0067, DRIVER REV: 2.15, SW REV: 2.15.290b, INT TEMP: 29.1 °C.
- Settings Status:** 10MHz: Int, RF IN: Direct.
- Measurement Mode:** Continuous, Limit Tester: Off.
- Channels Selected:** 406MHz, 121.5MHz, 243MHz, VIT.
- 15 Hex ID: 2788334E1EFFBF**
  - Protocol: Standard Location Serial ELT
  - Full Hex: FFFED093C419A70F322EF5E4F375128654CD
  - Burst Mode: Self test mode (long)
  - Date/Time: 2021-01-29 10:36:21 AM
- 406 Message Decode:**
  - 15 Hex Checksum: 824D3
  - Country Code: Canada (316)
  - Serial Number: 9999
  - C/S Number: 102
  - Bits 107 to 110: Default
  - Position Source: External GPS
  - Auxiliary Radio: 121.5 MHz
  - Latitude: 49.9222°
  - Longitude: -119.3944°
  - Model: NAT SATFIND-406
  - GPIRB
  - Δ Distance: 12,055,323 m
- RF Measurements:**
  - 406MHz:** Frequency (Int): 406.036940 MHz, Power: 16.0 dBm, Power Rise Time: 0.25 ms, Pre-Burst Level: -30.5 dBm, Repetition Period: ----, Bit Rate: 400.2 bps, Unmodulated CW: 160.0 ms, Transmission Time: 518.5 ms, Modulation Rise Time: 148.5 μs, Modulation Fall Time: 148.5 μs, Positive Phase: 1.05 rad, Negative Phase: -1.18 rad, Modulation Symmetry: 0.00 %
  - 121.5MHz:** Frequency (Int): 121.499938 MHz, Peak Power: 20.4 dBm, Sweep Direction: Upwards, Audio Frequency Upper: 1500, Audio Frequency Lower: 500, Audio Sweep Range: 1000, Sweep Rep Rate: 3.0 Hz, Modulation Index: 63.8 %, Duty Cycle: 38.9 %
- Graphics:** Three plots: Power vs Time (100dBm, 100ms/div), Spectrum (100dBm, 80kHz span), and Phase vs Time (0.5rad/div, 1.0ms/div).
- Details:**
  - Stability:** Short Term: ----, Med Term - Slope: ----, Med Term - Residual: ----, Nominal Frequency: ----, S1: 406036939.559, S2: 406036904.308, S3: 406036904.105
  - Leakage:** Measure Leakage button, Leakage Current: ----
- File View:** A list of burst files on the right side of the interface.

**Measurement – Basic** includes the Beacon Hex ID and all decode details, along with frequency and power of each selected channel.

**Detailed RF Measurements** includes detailed measurements for each selected channel.

**Stability** includes 406 MHz stability measurements in accordance with Cospas-Sarsat T.001.

**VIT** includes voltage, current, and temperature measurements sampled every 250 ms. (Note: VIT must be selected in Setup.)

**Leakage** is a separate measurement to measure the leakage current of the beacon.

**Graphics** will display the 406 MHz spectral mask, the 406 MHz power during the burst, and the 406 MHz phase modulation (FGB).

**AIS Details** includes all associated AIS messages in a dropdown list displaying all decode details along with AIS channel number, frequency, power, and transmission time.

**File View** displays all measurements contained in the **Measurement Files Location** determined in the Setup. Click on a measurement to view the data. A dropdown on Continuous mode measurements is available to select specific bursts within the measurement.

**File:**

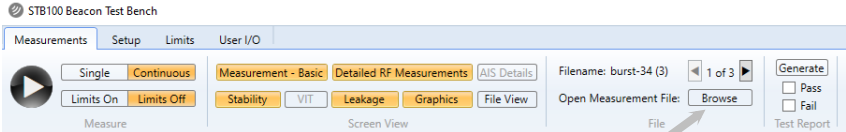

When running tests in Continuous mode, the filename will be appended with the measurement number in brackets. You can quickly view the previous measurements by pressing or holding down ◀ or ▶.

Clicking the **Browse** button will allow you to select a previously completed measurement.

## Test Report:

Use the buttons in the **Screen View** ribbon to display only the sections you wish to print on the Test Report. Click **Generate** to create a Test Report. You must have a suitable PDF viewer installed on your PC in order to view and print the Test Report. The Test Report is saved in the Measurement File location.

With **Limits ON** selected, the Test Report will show the measured value, the lower limit, the upper limit, and a pass or fail indication for each parameter selected in the Limits section of the **Setup** screen.

An image will be displayed in the top left-hand corner of the Test Report if you have selected **Enable Image In Test Report** in the **Report Header Logo** section of the **Setup** screen.

## VIT Configuration:

On the **Setup** screen, ensure that the VIT box is selected. Real-time VIT measurements will show on the right side of the VIT section.

## Zero Current Sensor:

The current sensor is a very sensitive device and may be adversely affected by external magnetic fields. In order to make accurate current measurements, the current sensor must be periodically zeroed. To zero the sensor, do the following:

- Ensure all loads are disconnected
- Press the Zero Current Sensor button on the **Setup** screen

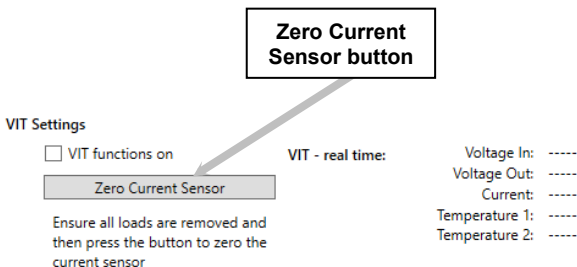

## VIT Measurements - General:

Voltage/Current/Temperature (VIT) measurements are done at various levels. When the VIT box is selected, the following VIT measurement methods are available:

- Real-time measurements are viewed from the **Setup** screen.
- VIT data is shown on the **Measurement** screen when an RF measurement is completed. This measurement corresponds to the voltage and current during the burst. This data is also recorded in the **filenameVIT.txt** file.
- When all frequency channels are unselected, the Measurement screen will display only VIT data once **Start** is clicked. The VIT data is sampled every 250 ms and continues until the user clicks **Stop** or the test duration is reached. The resulting data is saved in the **filenameVIT.txt** file.

## Voltage and Current Measurements:

Connect a power supply or battery to the **DC PWR IN** terminals on the rear of the STB100.

Connect the beacon to the **DC PWR OUT** terminals on either the front or rear of the STB100.

### Voltage:

The voltage drop between the **DC PWR IN** and **DC PWR OUT** terminals is approximately 100mV/A. The **V<sub>in</sub>** measurement represents the voltage at the DC PWR IN terminals, while the **V<sub>out</sub>** measurement represents the voltage at the DC PWR OUT terminals.

### Current – DC Overload Condition:

If the current exceeds approximately 9 Amps, the unit will go into a DC Overload condition. Remove the overload condition and press **Reset**

on the message box. You may need to cycle the power to the STB100 in order to reset.

### **Temperature:**

Temperature probes are available as an optional accessory from WST. VIT measurements will include temperature measurements when the probes are plugged in.

### **GPS Receiver:**

The STB100 is equipped with an internal GPS receiver. The GPS location is available via the **Get GPS Location** button in the **Setup** screen or if you have the **API Set** option. Please refer to the API Listing document.

Ensure the GPS antenna is connected to the **GPS ANT** connector on the rear of the STB100. Once the internal GPS receiver has location data, the green GPS ON LED on the faceplate will illuminate. Press **Get GPS Location** and the location will be entered into the **Latitude** and **Longitude** boxes. This information is used to provide a delta distance when location information is included in location protocol measurements.

## MAKING MEASUREMENTS

Once all of the items in the **Setup** section are completed, go to the **Measurement** screen by clicking on the **Measurements** tab.

### Connecting the Beacon:

There are three methods of receiving a signal from a beacon: using the Direct Connection mode, the Antenna mode, or the Screen Box mode.

#### Direct Connection:

- select **Direct** in the **Device Settings** on the **Setup** page.
- attach a 50Ω cable between the Beacon and the **RF-50Ω** connector located on the front of the STB100.

When a measurement is completed, the power level units will be shown in dBm. This measurement is very accurate. If **Cable Loss Factors** are entered on the **Setup** page, then these factors are included in the power level measurements.

### WARNING!

WHEN USING DIRECT CONNECTION INPUT MODE DO NOT EXCEED A BURST POWER LEVEL OF 20 WATTS OR A CONTINUOUS POWER LEVEL OF 2 WATTS. DAMAGE WILL RESULT!

#### Antenna:

- select **Antenna** in the **Device Settings** on the **Setup** page.
- ensure the antenna is attached to the **RF-ANT** connector on the front of the STB100.

When a measurement is completed, the power level units will be shown in %, with 100% being displayed when the tester is very close to the antenna of the transmitting beacon.

**Screen Box Connection:**

- select **Screen Box** in the **Device Settings** on the **Setup** page.
- attach a 50Ω cable from the output of the TSE100B Screen Box to the **RF IN** connector located on the front of the STB100.

**Single Mode Measurement:**

Click **Start**. The ribbon will show the **Oscillograph**, the **406 Burst Timer** and the **Elapsed Time**, along with a **Receive Indicator** for each channel. A check mark will appear in the appropriate **Indicator** box once the signal is received.

The number inside the **406 Burst Timer** will reset to zero after each 406 burst. The rotating indicator on the circumference of the circle is timed for 50 seconds.

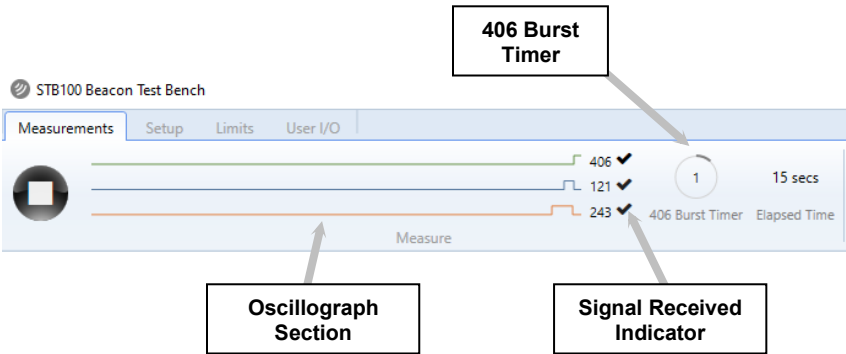

The 121, 243, and AIS signals must be received before a 406 burst. The measurement is deemed to be completed once the 406 burst is received.

Once the measurement is completed, the result will be displayed on the **Measurement** screen.

## Continuous Mode Measurement:

Click **Start**. The ribbon will show the **Oscillograph**, the **406 Burst Timer**, the **Elapsed Time**, the **Time Remaining** (if the Test Duration box has been selected in Setup), along with a **Receive Indicator** for each channel. A check mark will appear in the appropriate Indicator box once the signal is received.

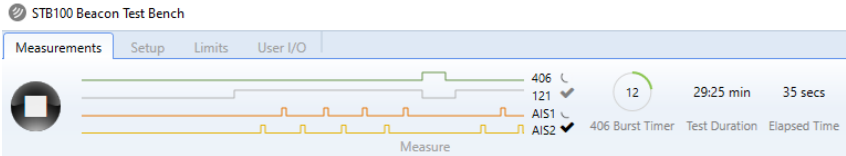

The 121, 243, and AIS bursts must be received before a 406 burst. The measurement is deemed to be completed once a 406 burst is received.

Once the measurement is completed, the result will be displayed on the **Measurement** screen. Once two or more bursts have been received, the measurement number in brackets is appended to the filename.

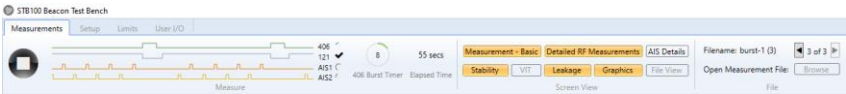

The user may scroll through previous measurement results while waiting for the next measurement.

The measurement will terminate once the user clicks the **Stop** button or the **Test Duration** reaches zero.

**Note: In Continuous mode, when using the Antenna mode, all beacons within range of the STB100 will be captured. The Hex IDs may not necessarily be the same.**

## Leakage Measurement:

Once a measurement is completed, the user may make a leakage measurement. This will measure the leakage current in the beacon when it is switched to auto or standby.

- Ensure the beacon is in its standby or auto mode
- Click the **Measure Leakage** button.

The screenshot shows the STB100 Beacon Test Bench software interface. The main display area shows the following information:

- Device Status:** Connected
- MODEL:** STB100-100
- S/N:** 60001
- CAL DUE DATE:** 2022-12-14
- FW REV:** 0003.0067
- DRIVER REV:** 2.15
- SW REV:** 2.15.290b
- INT TEMP:** 29.0 °C
- Settings Status:** 10MHz: Int, RF IN: Direct
- Measurement Mode:** Single, Limit Tester: Off
- Channels Selected:** 406MHz, 121.5MHz

The main display area shows the following information:

- 15 Hex ID: 2788334E1EFFBFF**
- Protocol:** Standard Location Serial ELT
- Full Hex:** FFED093C419A70F322EF5E4F375128654CD
- Burst Mode:** Self test mode (long)
- Date/Time:** 2021-01-29 10:36:21 AM

The **406 Message Decode** section shows:

- 15 Hex Checksum: 824D3
- Country Code: Canada (316)
- Serial Number: 9999
- C/S Number: 102
- Bits 107 to 110: Default
- Position Source: External GPS
- Auxiliary Radio: 121.5 MHz
- Latitude: 49.9222°
- Longitude: -119.3944°
- Model: NAT SATFIND-406
- GP18
- Δ Distance: 12,055,323 m

The **RF Measurements** section shows:

- 406MHz:** Frequency (Int): 406.036940 MHz, Power: 16.0 dBm, Power Rise Time: 0.25 ms, Pre-Burst Level: -30.5 dBm, Repetition Period: ----, Bit Rate: 400.2 bps, Unmodulated CW: 160.0 ms, Transmission Time: 518.5 ms, Modulation Rise Time: 148.5 μs, Modulation Fall Time: 148.5 μs, Positive Phase: 1.05 rad, Negative Phase: -1.18 rad, Modulation Symmetry: 0.00 %
- 121.5MHz:** Frequency (Int): 121.499938 MHz, Peak Power: 20.4 dBm, Sweep Direction: Upwards, Audio Frequency Upper: 1500, Audio Frequency Lower: 500, Audio Sweep Range: 1000, Sweep Rep Rate: 3.0 Hz, Modulation Index: 83.8 %, Duty Cycle: 38.9 %

The **Graphics** section shows three plots: Power vs Time, Spectrum, and Phase vs Time.

The **Details** section shows:

- Stability:** Short Term: ----, Med Term - Slope: ----, Med Term - Residual: ----, Nominal Frequency: ----
- Leakage:** Measure Leakage (button), Leakage Current: ----

A callout box points to the **Measure Leakage** button.

# MEASUREMENT RESULTS

## Results Screen:

Once the measurement is completed, the results show on the Measurement screen. The user can toggle various sections On and Off.

Summary section

**15 Hex ID: 2788334E1EFFBFF**

Protocol: Standard Location Serial ELT  
Full Hex: FFFED093C419A70F32EF5E4F375128654CD  
Burst Mode: Self test mode (long)  
Date/Time: 2021-02-03 3:07:03 PM

**406 Message Decode**

15 Hex Checksum: 824D3  
Country Code: Canada (316)  
Serial Number: 9999  
C/S Number: 102  
Bits 107 to 110: Default  
Position Source: External GPS  
Auxiliary Radio: 121.5 MHz  
Latitude: 49.9222°  
Longitude: -119.3944°  
Model: NAT SATFIND-406  
GNSS  
Δ Distance: 12,055.323 m

**RF Measurements**

406MHz	121.5MHz	243MHz
Frequency (Int): 406.036923 MHz	Frequency (Int): 121.499961 MHz	Frequency (Int): 242.999921 MHz
Power: 16.0 dBm	Peak Power: 20.5 dBm	Peak Power: 14.3 dBm
Power Rise Time: 0.25 ms	Sweep Direction: Upwards	Sweep Direction: Upwards
Pre-Burst Level: -30.7 dBm	Audio Frequency Upper: 1500	Audio Frequency Upper: 1500
Repetition Period: -----	Audio Frequency Lower: 500	Audio Frequency Lower: 500
Bit Rate: 399.9 bps	Audio Sweep Range: 1000	Audio Sweep Range: 1000
Unmodulated CW: 159.8 ms	Sweep Rep Rate: 3.0 Hz	Sweep Rep Rate: 3.0 Hz
Transmission Time: 518.5 ms	Modulation Index: 83.7 %	Modulation Index: 65.7 %
Modulation Rise Time: 138.6 μs	Duty Cycle: 39.1 %	Duty Cycle: 39.0 %
Modulation Fall Time: 148.5 μs		
Positive Phase: -1.10 rad		
Negative Phase: -1.10 rad		
Modulation Symmetry: 0.00 %		

**Graphics**

Power vs Time | Spectrum | Phase vs Time

**Details**

Stability	VIT	Leakage
Short Term: -----	Voltage In: 0.000 V	Measure Leakage
Med Term - Slope: -----	Voltage Out: 0.000 V	Leakage Current: 0.000 μA
Med Term - Residual: -----	Current: 0.000 A	
Nominal Frequency: -----	Temperature 1: -----	
S1: 406036923.300	Temperature 2: -----	
S2: 406036923.233		
S3: 406036923.221		

## TEST REPORTS AND DATA FILES

### Generate and Print Test Report:

Use the buttons in the **Screen View** ribbon to display only the sections you wish to print on the Test Report. In the **Test Report** ribbon, click **Generate** to create a test report. You must have a suitable PDF viewer installed on your PC in order to view and print the Test Report. The Test Report is also saved in the Measurement File location.

With the **Limits ON**, the Test Report will show the measured value, the lower limit, the upper limit, and a pass or fail indication for each parameter selected in the **Limits** section of the **Setup** screen.

With the **Limits OFF**, the user can manually enter Pass or Fail before clicking Generate. The Pass or Fail will be shown on the Test Report.

If **Enable Image In Test Report** is selected in **Report Header Logo** section of the Setup screen, the image will be placed in the top left corner of the generated beacon report.

### Data Files:

Each measurement generates a folder containing the measurement data. The measurement data includes a data file containing all of the protocol data and RF measurement data, and a VIT data file containing the VIT data. Both files are in TXT format for easy importing into a spreadsheet and for data parsing.

Measurement results are stored on the PC in the directory location specified on the **Setup** screen. Each measurement will be saved in a folder with the same name as the measurement filename. For example, a measurement with the filename "Burst-1" is made on a beacon. When the measurement is completed, the following is created:

<b>&lt;Burst-1&gt;</b>	folder name
<Graphics>	folder containing graphics
Burst-1.txt	main delimited data file
Burst-1AIS.txt	delimited AIS data file
Burst-1VIT.txt	delimited VIT data file
Burst-1.pdf	PDF Test Report

## **Main Measurement Data File Structure:**

The Measurement Data file is a delimited text file (TXT format) suitable for importing into a spreadsheet or database.

The header section of the file contains the Filename; Unit Model Number & Serial Number; Cal Due Date; Tester Internal Temperature; Input Mode; Reference Mode; Cable Loss at 406; Cable Loss at 121; Cable Loss at 243; Receive Channels; FW/Driver Revisions; Organization; Tested By; Date/Time.

## **First Generation Beacon (FGB) File Structure:**

The body contains the Delta Time (s); Burst#; 15 Hex ID; Full HEX; Latitude; Longitude; 406 Freq (MHz); 406 Power (%); 406 Power Rise Time (ms); 406 Pre-Burst Level (dBm); 406 Rep Period (s); 406 Bit Rate (bps); 406 Unmodulated CW Time (ms); 406 Transmission Time (ms); 406 Mod Rise Time (us); 406 Mod Fall Time (us); 406 Positive Phase (rad); 406 Negative Phase (rad); 406 Phase Symmetry (%); S1; S2; S3; 406 Short Term Stability; 406 Medium Term Stability – Mean Slope; 406 Medium Term Stability – Residual; 406 Nominal Frequency; 121 Freq (MHz); 121 Peak Power (%); 121 Sweep Direction; 121 Audio Freq Upper (Hz); 121 Audio Freq Lower (Hz); 121 Audio Sweep Range (Hz); 121 Mod Index (%); 121 Sweep Rep Rate (Hz); 121 Duty Cycle (%); 243 Freq (MHz); 243 Peak Power (%); 243 Sweep Direction; 243 Audio Freq Upper (Hz); 243 Audio Freq Lower (Hz); 243 Audio Sweep Range (Hz); 243 Mod Index (%); 243 Sweep Rep Rate (Hz); 243 Duty Cycle (%); Full Binary; Description; Temperature 1; Temperature 2.

## **Second Generation Beacon (SGB) File Structure:**

Delta Time (s); Burst#; 23 Hex ID; Full HEX; Latitude; Longitude; 406 Freq (MHz); 406 Power (%); 406 Bit Rate (bps); 406 Chip Rate (cps); 406 Chip Rate Variation (cps<sup>2</sup>); 406 IQ Relative Offset (%); 406 IQ PN Sequence; 406 Pre-Burst Level (dBm); 406 Transmission Time (ms); 406 Power Rise Time (ms); 406 Power Fall Time (ms); 406 Short Term Stability; 406 Rep Period (s); 406 EVM (%); 406 Peak-to-Peak Amplitude (%); 406 Post-Burst Level (dBm); 406 Out-of-Band Emissions (%); 121 Freq (MHz) (%); 121 Peak Power; 121 Sweep Direction; 121 Audio Freq Upper (Hz); 121 Audio Freq Lower (Hz); 121 Audio Sweep Range (Hz); 121 Mod Index (%); 121 Sweep Rep Rate (Hz); 121 Duty Cycle (%); 243 Freq (MHz) (%); 243 Peak Power; 243 Sweep Direction; 243

Audio Freq Upper (Hz);243 Audio Freq Lower (Hz);243 Audio Sweep Range (Hz);243 Mod Index (%);243 Sweep Rep Rate (Hz);243 Duty Cycle (%);Full Binary; Description; Temperature 1;Temperature 2

Note: All power measurement units are in dBm for **Direct Input** mode and in % for **Antenna** or **Screen Box** Input modes.

When the Tester is in **Continuous Mode**, each set of measurement data will be appended to the measurement data file.

### **AIS Measurement Data File Structure:**

The AIS Data file is a delimited text file (TXT format) suitable for importing into a spreadsheet or database.

The header section of the file contains the Filename; Unit Model Number & Serial Number; Cal Due Date; Tester Internal Temperature; Input Mode; Reference Mode; Cable Loss at AIS; Receive Channels; FW/Driver Revisions; Organization; Tested By; Date/Time.

The body contains the Delta Time (s); Channel Number; Message #; Frequency; Power; Transmission Time; Latitude; Longitude; Description; Full Hex.

### **VIT Data File Structure:**

The VIT Data file is a delimited text file (TXT format) suitable for importing into a spreadsheet or database.

The header section of the file contains the Filename; Unit Model Number & Serial Number; Cal Due Date; Tester Internal Temperature; FW/Driver Revisions; Organization; Tested By; Date/Time.

The body contains the Delta Time; Current; Vin; Vout; Temperature 1; Temperature 2.

### **Graphics Files:**

The Graphics folder contains the data used for the graphics files. This data represents each Graphic plot with 200 data points in a TXT format, along with a PNG format graphic for each measurement.

# USER I/O SCREEN

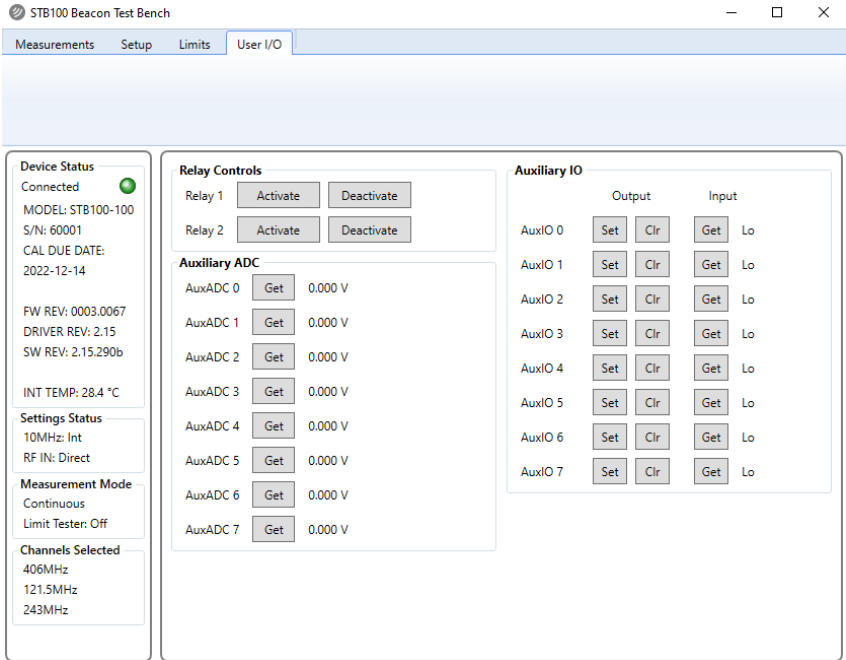

The STB100 is equipped with useful features in the USER IO section. These include:

- 2 Relays
- 8 Auxilliary ADC lines (0-12V)
- 8 Auxillary I/O lines (logic level)

These features can be used statically here. Those users that purchase the **API Set** option can integrate these features into their own customized software.

Click on the **USER IO** tab. This screen allows control of the Relays, Auxiliary ADC, and Auxillary I/O lines.

## Breakout Board and Cable:

In order to make it easier to integrate USER IO functions, a Breakout Board and Cable are available from WST. The part number is 850-BB100.

## AIS TRANSCEIVER MEASUREMENTS

AIS Transceiver Measurement functionality is only available with the AIS (Rx&Tx) option. Both Class A and Class B AIS transceivers can be measured. No attenuator is required between the AIS transceiver and the STB100.

### General:

The user must add the AIS transceiver information before making measurements. The STB100 software will keep a list of previously added transceivers which can easily be recalled.

The measurements can be made using a measurement wizard via the **Auto Test Button**, or alternatively, the user can manually select each individual test. The results from each test will be automatically inserted into the appropriate section of the IMO AIS Test Report in accordance with IMO MSC.1/Circ.1252.

Measurements are made with the AIS transceiver connected directly to the STB100 via a 50Ω coaxial cable, except for Section 6, *On Air Performance Test*, when the AIS transceiver uses its normal antenna. The 50Ω coaxial cable (WST p/n 130-031) and an optional UHF to BNC adapter (WST p/n 385-UHF-101) are available from WST.

### Application Screens:

The **AIS** section has three main screens: the **IMO Test** screen, the **Individual Tests** screen, and the **Setup** screen, each accessible from the tabs near the top of the screen.

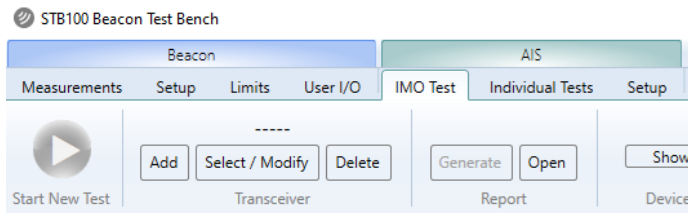

## IMO Test screen:

STB100 Beacon Test Bench

Beacon AIS

Measurements Setup Limits User I/O IMO Test Individual Tests Setup

Start New Test Add Select / Modify Delete Generate Open Show Hide

Transceiver Report Device Status Panel

**Device Status**  
 Connected  
 MODEL: STB100-120  
 S/N: 6001  
 CAL DUE DATE:  
 2022-12-14  
 FW REV: 0003.0067  
 DRIVER REV: 2.15  
 SW REV: 2.15.290b  
 INT TEMP: 29.3 °C

**Settings Status**  
 10MHz: Int  
 RF IN: Direct

**Pilot Plug**  
 Not Connected

**Transceiver**

**Station**  
 MMSI Number: \_\_\_\_\_  
 Manufacturer: \_\_\_\_\_  
 Model: \_\_\_\_\_  
 Serial Number: \_\_\_\_\_  
 Type: \_\_\_\_\_

**Ship**  
 Name of Ship: \_\_\_\_\_  
 Port of Registry: \_\_\_\_\_  
 Gross Tonnage: \_\_\_\_\_  
 Date Keel Laid: \_\_\_\_\_  
 IMO Number: \_\_\_\_\_

**Test History**  
 Modify Delete

**Test Details**  
 Measurement Summary Test Steps Summary

## Individual Tests screen:

STB100 Beacon Test Bench

Beacon AIS

Measurements Setup Limits User I/O IMO Test Individual Tests Setup

Add Select / Modify Delete Connect AIS1 AIS2

Transceiver Pilot Plug AIS Tx Channel

Not Connected  
 Direct  
 Antenna  
 Screen Box  
 RF Input Mode

**Device Status**  
 Connected  
 MODEL: STB100-120  
 S/N: 60001  
 CAL DUE DATE:  
 2022-12-14  
 FW REV: 0003.0067  
 DRIVER REV: 2.15  
 SW REV: 2.15.290b  
 INT TEMP: 29.3 °C

**Settings Status**  
 10MHz: Int  
 RF IN: Direct

**Pilot Plug**  
 Not Connected

**Tests**  
 Receive AIS Message  
 Receive AIS Message 3  
 Receive AIS Message 5  
 Receive AIS Message 11  
 Receive AIS Message 18  
 Receive AIS Message 24  
 Send AIS Message 1  
 View Pilot Plug Data

Start Clear Display

**Results**

**Activity Log**

# Setup screen:

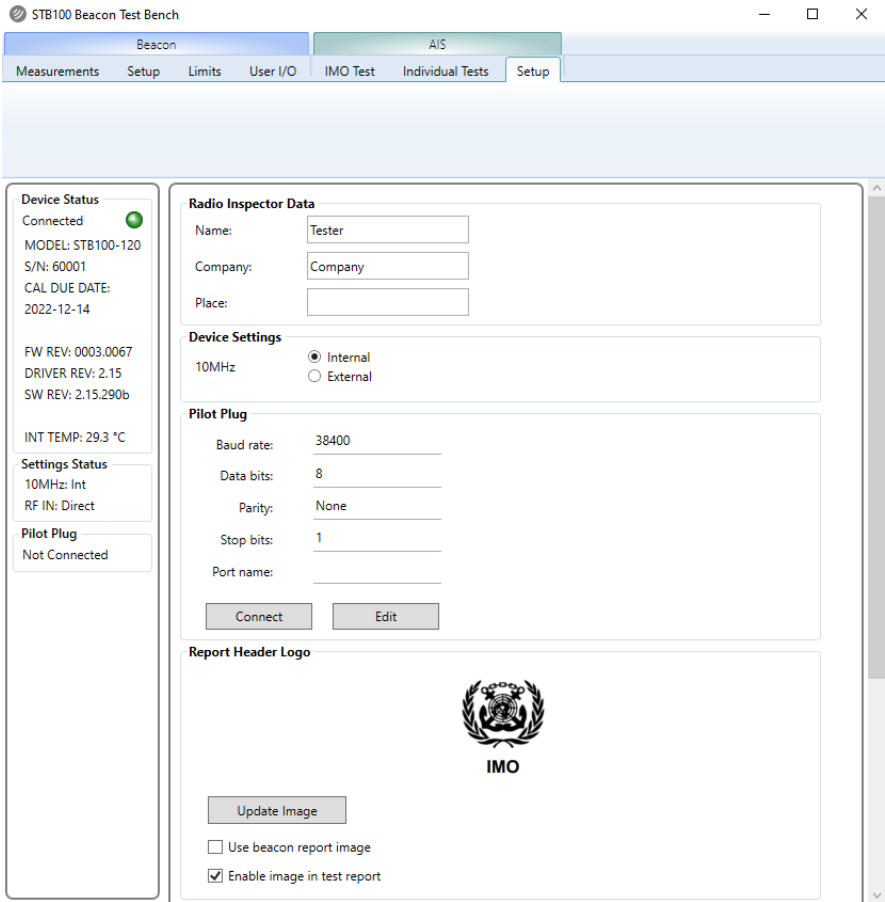

## Device Status Panel:

Each of the three screens has the Device Status panel on the left side which shows the user various device settings and the status of various functions.

## IMO Test Configuration:

The ribbon in the **IMO Test** screen has the following sections: Start New Test; Transceiver; Report; and Device Status Panel.

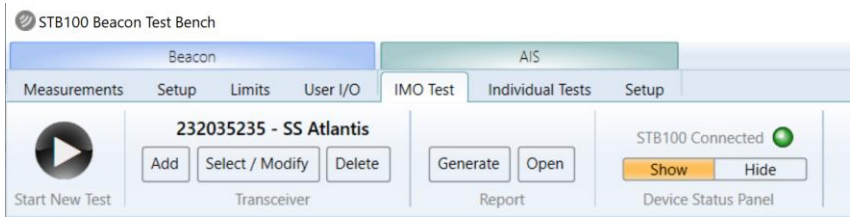

## Transceiver:

The **Add** button will open up a new window where users enter information on the AIS transceiver to be tested.

The screenshot shows a dialog box titled 'Add Transceiver'. It is divided into two columns: 'Station Info' and 'Ship Info'. Under 'Station Info', there are fields for 'MMSI Number:', 'Manufacturer:', 'Model:', 'Serial Number:', and 'Type:'. The 'Type:' field is a dropdown menu currently showing 'AIS Class A'. A red exclamation mark is visible next to the 'MMSI Number:' field. Under 'Ship Info', there are fields for 'Name of Ship:', 'Port of Registry:', 'Gross Tonnage:', 'Date Keel Laid:', and 'IMO Number:'. The 'Date Keel Laid:' field has a date picker showing '15'. At the bottom right of the dialog box are three buttons: 'Auto Fill', 'Save', and 'Close'.

Press **Auto Fill**. The receiver will wait for the Transceiver signal transmission and extract the necessary details. Alternatively, the user manually completes the information, then clicks **Close**.

The **Select/Modify** button will allow users to select a Transceiver from a list of previously tested AIS Transceivers to be tested or to modify the current Transceiver data.

In the **Select/Modify** window, the **Select** button will select the highlighted transceiver. Double-clicking will also select a Transceiver.

In the **Select/Modify** window, the **Modify** button allows users to edit a previously created Transceiver.

Each Transceiver in the list will display the MMSI number, Ship Name, and how many Tests are associated with that ship. Navigate through pages of Transceivers by clicking the arrows. Each page will show a maximum of 10 Transceivers.

The **Delete** button will allow users to delete a selected Transceiver.

**Note:** All Tests must be deleted from a Transceiver before deletion can occur.

**Start New Test:**

The **Start New Test** button creates a new IMO Test and opens up a new **IMO Test Summary** window based on the selected Transceiver.

The **IMO Test Summary** is the main window for running IMO tests and inputting IMO test data.

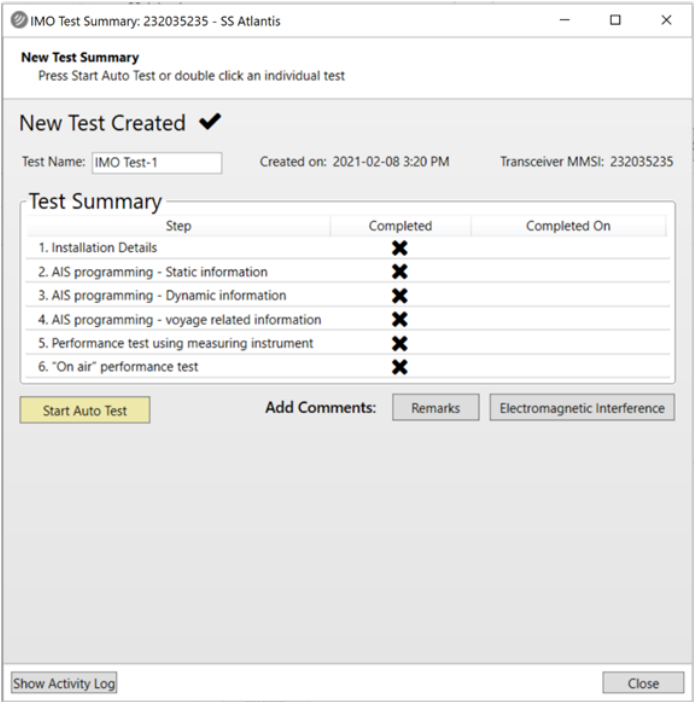

The **IMO Test Summary** window allows users to change the **Test Name**, start an **Auto Test**, view the **Activity Log** window, add **Test Remarks**, add **Electromagnetic Interference Comments**, view completion of individual test steps, and navigate to each section of the IMO Test Report.

The **Test Name** will auto generate to the name entered in the **IMO Test** section in the **Setup** tab. It can also be edited here.

The **Show Activity Log** button allows users to show and hide the activity information regarding the current test.

The **Remarks** and **Electromagnetic Interference** buttons open a text box to allow the user to enter information. Information that has been entered here will be shown in the appropriate sections of the IMO test report. **Remarks** and **Electromagnetic Interference** data can also be modified in the **Test Steps Summary** section under **Comments** in the **IMO Test** tab.

## Report:

The **Generate** button will generate an **IMO Test Report** for the selected test. The IMO test generated is based on standards according to IMO SN/Circ.227 and resolution MSC.74 (69), annex 3.

Reports will be saved in the folder named '**../(Transceiver MMSI) – (Transceiver ship name)/**'.

The test report will be saved as '**(Test date created)-(Test Name).pdf**' by default. Options to change the default test name, auto increment test name, and remove the date from the filename are located in the **Setup** screen under the **IMO Test** section.

Options to update the **IMO Test Report** image, disable showing an image in the **IMO Test Report**, or use the Beacon report image are located in the **Setup** screen under the **Report Header Logo** section.

The **Open** button will open the file location where reports are saved for the selected transceiver. If a transceiver is not selected, the button will open at '**../(Transceiver MMSI) – (Transceiver ship name)/**'.

## Device Status Panel:

The **Show** and **Hide** buttons allow users to show or hide the **Device Status** panel on the left side of the screen.

## Main IMO Test Screen:

Once the tests are completed or Close has been pressed on the IMO Test Screen page, the Main IMO Test Screen appears.

The screenshot displays the STB100 Beacon Test Bench software interface. The main window title is "STB100 Beacon Test Bench". The interface is divided into several sections:

- Transceiver Section:** Displays details for the selected transceiver, "232035235 - SS Atlantis". It includes fields for Station (IMMSI Number: 232035235, Manufacturer: McMurdo, Model: M5, Serial Number: 123456, Type: AIS Class A) and Ship (Name of Ship: SS Atlantis, Port of Registry: Spain, Gross Tonnage: 5000, Date Keel Laid: 2021-02-01, IMO Number: 654321).
- Test History Section:** Shows a list of recent tests with columns for date, time, and name (e.g., 2021-02-09 4:55 PM Name: IMO Test-3).
- IMO Test-3 Details Section:** Contains a "Measurement Summary" with details for Message 3 (Direct) and Message 3 (Antenna), including channel, frequency, power, and transmission time. It also includes a "Test Steps Summary" with a checklist of 6 items, all marked as complete (green checkmarks). Below this is a "1. Installation Details" section with a checklist of 19 items, all marked as "Yes".

The main **IMO Test Screen** displays information based on the selected transceiver; test history associated with the selected transceiver; and a details section that includes measurement and IMO test related data for a selected test.

### *Transceiver:*

Information in this section will display read-only data of the selected Transceiver.

*Test History:*

The **Test History** section allows users to **Modify** or **Delete** existing tests associated with the selected transceiver. Clicking the arrows will load more pages of tests. Tests are ordered by the newest created. Add a new test by clicking the **Start New Test** button in the ribbon.

The **Modify** button will open up an **Existing Test Summary** window.

The **Delete** button will prompt the user by asking if they are sure they want to delete the Test before deleting.

*Test Details:*

The **Test Details** section includes a **Measurement Summary** section and a **Test Steps Summary** section.

The **Measurement Summary** section includes the received AIS measurements and decoded data for the selected test.

The **Test Steps Summary** section includes a selectable list of IMO test sections. Clicking on one of the test sections in the list will display related test data underneath. The **Modify** button will take the user to the **Existing Test Summary** window for the selected individual test. The **Comments** option allows users to view and modify the **Remarks** and **Electromagnetic Interference** fields.

**Individual Tests Screen Configuration:**

The ribbon in the **Individual Tests** screen has the following sections: Transceiver; Pilot Plug; AIS Tx Channel; and RF Input Mode.

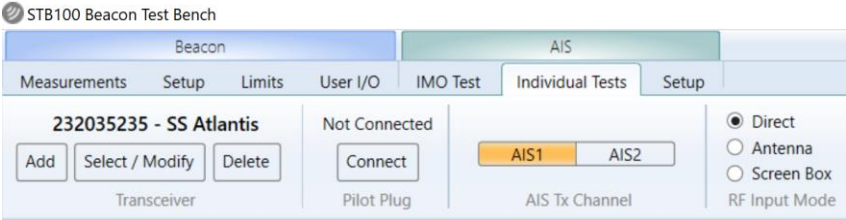

## **Transceiver:**

The **Transceiver** section in the ribbon has the exact same functionality as the **Transceiver** section in the **IMO Test** screen's ribbon.

## **Pilot Plug:**

The **Connect** button will connect or disconnect a Transceiver Pilot Plug connection. If an error occurs during connection, an error window will be displayed to the user displaying the error.

Configuration for connecting to a pilot plug can be adjusted in the **Setup** screen under the **Pilot Plug** section.

**Note:** Viewing pilot plug data can be done using the '**View Pilot Plug Data**' test.

## **AIS Tx Channel:**

Allows users to toggle between channels AIS1 or AIS2 before running tests.

## **RF Input Mode:**

Allows users to manually switch the STB100 input mode before running tests. This section will also switch the AIS Tx mode to the selected mode.

# Main Individual Test Screen:

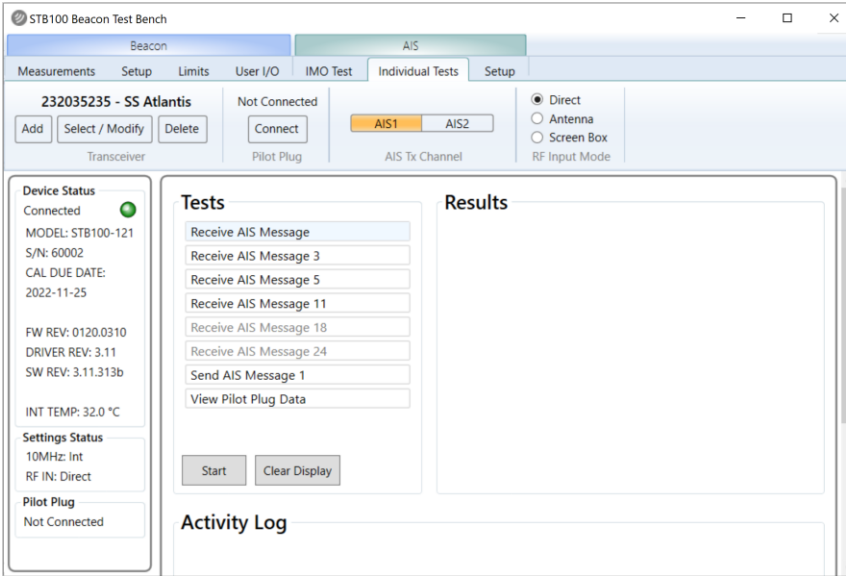

The main **Individual Test** screen allows users to run individual tests associated with AIS transceivers. This screen has 3 sections: Tests; Results; and Activity Log.

### Tests:

The **Tests** section contains a list of all available tests to run on an AIS transceiver. With no active transceiver selected in the **Transceiver** section, only the 'Receive AIS message', 'Send AIS Message 1', and 'View Pilot Plug Data' options will be available.

**Note:** The 'Receive AIS message' test will receive and display the next available AIS message in the **Results** section.

If a Class A AIS transceiver is selected, options 'Receive AIS message 3', 'Receive AIS message 5', and 'Receive AIS message 11' become available to use. Likewise, when a Class B AIS transceiver is selected, options 'Receive AIS message 18', 'Receive AIS message 24' become available to use.

All tests have **Start** and **Clear Display** buttons, which respectively start the selected test and reset the data in the **Results** and **Activity Log** sections.

The 'View Pilot Plug Data' test enables the **Save to File** and **Pop Out** buttons.

The **Pop Out** button opens a new window to view Pilot Plug data.

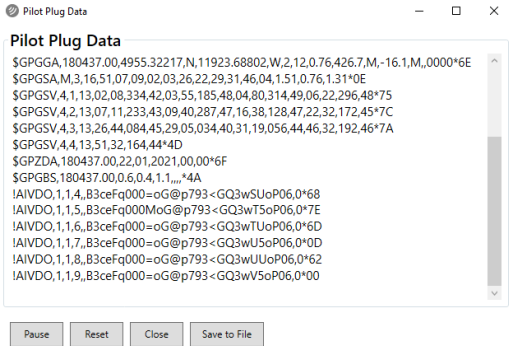

**Note:** Please verify if the **Pilot Plug** configuration in the AIS Setup screen is correct before connecting to the **Pilot Plug**.

The **Save to File** button will become enabled when **Pilot Plug** data is present. The Pilot Plug data will be saved to a file located at './Pilot Plug Data/'. The name format of each file generated will be 'yyyymmddhhmmss-PilotPlugData.txt'.

**Results:**

The received AIS message from the selected test as well as **Pilot Plug** data will display in this section.

**Activity Log:**

The **Activity Log** section will display the processes taking place in the STB100 while running tests.

**Setup Screen Configuration:**

Go to the AIS **Setup Screen** by clicking on the **Setup tab** under the AIS header.

The **Setup Screen** has the following sections: Radio Inspector Data; Device Settings; Files; Pilot Plug; Report Header Logo; IMO Test; and Individual Tests.

**Radio Inspector Data:**

Enter the **Name** of the user performing the tests. Enter the name of the **Company**. Enter the **Place** where the test is taking place. This data will appear at the bottom of a generated *IMO Test Report*.

**Device Settings:**

Select the desired **Internal** or **External** 10 MHz reference. The external 10 MHz must have a stability better than 10E-10.

**Files:**

Click **Browse** to enter the desired location where all AIS files and reports will be located. Default location is 'C:\WST\STB100 – AIS'.

**Pilot Plug:**

Click **Edit** to modify the Pilot Plug connection settings. Baud rate, Data bits, parity, and stop bits are all default to common connection rate settings for Pilot Plug to USB connections.

Port name requires users to locate and find the correct Pilot Plug COM port. Users can find this information by opening up Device Manager and dropping down the 'Ports (COM & LPT)' section. Once open, this section will update every time a COM port is connected and disconnected. Once you have confirmation on your pilot plug COM port, select it from the **Port Name** dropdown and click **Save**.

If a user clicks **Connect** and a connection could not be made to the Pilot Plug COM port, a detailed error message will display information on the cause of the issue.

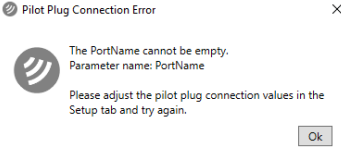

## Report Header Logo:

Click **Update Image** to select an image to be displayed at the top of an IMO test report.

Toggle **Use beacon report image** to enable or disable the use of the image selected in the **Beacon Setup** screen.

Toggle **Enable image in test report** to enable or disable displaying the selected image in a *Beacon Test Report*.

## IMO Test:

Enter the desired test name in the **Default test name** box. When **Auto increment test name** is selected, the test name will be appended with a number. This number will automatically increment with each test. The user can specify a custom auto increment number by placing '-#' at the end of the default test name. The # is the auto increment starting number.

Toggle **Remove date from filename** to enable or disable adding the current date and time to the start of the IMO report saved filename.

## Individual Tests:

Select either AIS1 or AIS2 in **AIS Tx channel** to select the STB100 AIS transmitting channel.

The **Clear individual tests from database** button will delete all data in the **Measurement** table. All measurements that fall under this condition will be measurements that were saved to the database via an individual test.

The **Setup STB100 Tx AIS Message** button allows users to modify the AIS Message 1 data transmitted by the STB100. Information on AIS Message 1 and the acceptable adjusted parameter values can be found at <https://www.navcen.uscg.gov/?pageName=AISMessagesA>.

AIS Message 1 can be sent by selecting the **Send AIS Message 1** test in the **Individual Tests** screen.

# MAKING AIS MEASUREMENTS

You can use the **Auto Test** which will prompt you for various actions until all the tests are completed, or you can complete the tests manually by individually selecting each test.

## Auto Testing:

Press the **Start Auto Test** button to begin requesting and receiving the appropriate AIS measurement data based on the selected AIS transceiver. A series of popup windows will direct the user on the proper STB100 and AIS transceiver setup for the current test. Each section of the Auto Test will make 3 attempts if it is not successful. All AIS measurement tests in sections 2 to 5 in the **Test Summary** are run in **Direct connection** mode. The section 6 AIS measurement test will be run in **Antenna** mode.

## Manual Testing:

Double-clicking a **Step** in the **Test Summary** list will navigate the user to the selected individual test.

### 1. Installation Details:

IMO Test Summary: 232035235 - SS Atlantis

**1. Installation Details**  
Please fill out answers to questions

1.1 AIS transponder type:	AIS Class A
1.2 Type approval certificate	Yes
1.3 Initial installation configuration report on board?	Yes
1.4 Drawing approved?	Yes
1.5 Main source of electrical power	AC <input type="checkbox"/> Leave blank
1.6 Emergency source of electrical power	Generator <input type="checkbox"/> Leave blank
1.7 Capacity to be verified if the AIS is connected to a battery	Yes
1.8 Pilot plug near pilots operating position?	Yes
1.9 120 V AC provided near pilot plug?	Yes

Test Complete: ✓

Go To Summary Page

Close

Section 1.1 auto selects the transceiver type based on which AIS transceiver class was specified when creating the associated transceiver.

Section 1.5 and 1.6 require users to manually fill out these sections. These sections on the *IMO Test Report* will be left empty if the **Leave Blank** checkbox has been selected. 'N/A' will display on the *IMO Test Report* if no data has been entered and the **Leave Blank** option is unselected.

All other sections have a dropdown list of values to choose from. Leaving a dropdown option unselected will result in 'N/A' displaying on the *IMO Test Report*.

The **Go To Summary Page** button will return to the **Test Summary** window.

## 2. AIS Programming – Static Information:

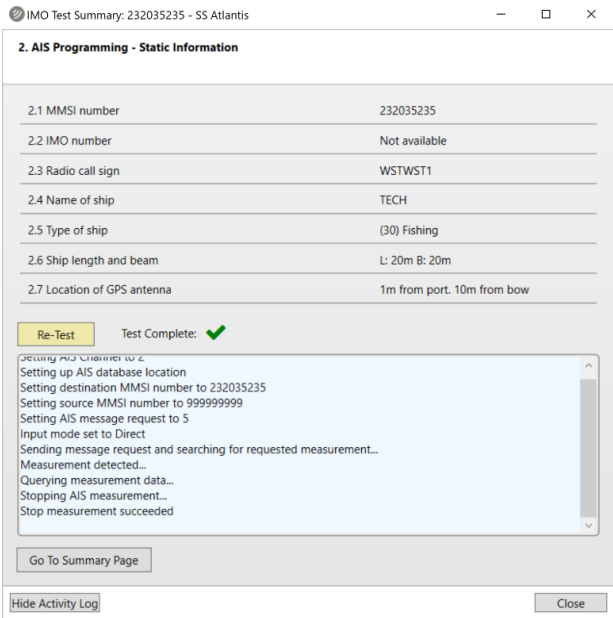

The **Test** button will start interrogating the selected AIS transceiver for the section 2 AIS message.

The AIS measurement test in section 2 is run in **Direct Connection** mode.

### 3. AIS Programming – Dynamic Information:

IMO Test Summary: 232035235 - SS Atlantis

#### 3. AIS Programming - Dynamic Information

3.1 Ships position with accuracy and integrity status	Position Accuracy: Low Longitude: -119.3952° Latitude: 49.9220°
3.2 Time in UTC	16s
3.3 Course over ground (COG)	Not available
3.4 Speed over ground (SOG)	0.8 knots
3.5 Heading	Not available
3.6 Navigation status	Constrained by her draught
3.7 Rate of turn, where available (ROT)	Not available
3.8 Angle of heel, pitch and roll, where available	N/A

**Re-Test**      Test Complete:

Setting AIS message request to 5  
Input mode set to Direct  
Sending message request and searching for requested measurement...  
Measurement detected...  
Querying measurement data...  
Stopping AIS measurement...  
Stop measurement succeeded

**Go To Summary Page**

**Hide Activity Log**      **Close**

The **Test** button will start interrogating the selected AIS Transceiver for the Section 3 AIS message.

The AIS measurement test in section 3 is run in **Direct Connection** mode.

#### 4. AIS Programming – Voyage Related Information:

IMO Test Summary: 232035235 - SS Atlantis

#### 4. AIS Programming - Voyage Related Information

4.1 Ships draught	25.6m
4.2 Type of cargo	N/A
4.3 Destination and ETA	Destination: PARIS ETA: 12240807 UTC
4.4 Route plan	N/A
4.5 Short safety-related messages (message 14)	N/A

Re-Test Message 5    Test Message 14    Test Complete:

```
stop measurement succeeded
Attempt 1 failed

Setting AIS Channel to 2
Setting up AIS database location
Setting destination MMSI number to 232035235
Setting source MMSI number to 999999999
Setting AIS message request to 5
Input mode set to Direct
Sending message request and searching for requested measurement...
Measurement detected...
Querying measurement data...
Stopping AIS measurement...
Stop measurement succeeded
```

Go To Summary Page    Hide Activity Log    Close

Section 4.5 requires a user to actively transmit a safety-related message (SRM) from the selected AIS Transceiver. To complete this section, click the **Test Message 14** button and transmit AIS message 14 from the selected transceiver. Please refer to the Transceiver's instruction manual for information on sending the SRM Message 14. Once Message 14 has been received, section 4.5 will update to 'OK'.

The **Test Message 5** button will start interrogating the selected AIS Transceiver for AIS message 5.

The AIS measurement tests in section 4 are run in **Direct Connection** mode.

## 5. Performance Test:

IMO Test Summary: 232035235 - SS Atlantis

### 5. Performance Test

5.1 Frequency measurements	Channel AIS1: 161.975204 MHz Channel AIS2: 162.025197 MHz
5.2 Transmitting output	Channel AIS1: 41.5 dBm Channel AIS2: 41.4 dBm
5.3 Polling information Ch. 70	N/A
5.4 Read data from AIS	OK
5.5 Send data to AIS	OK
5.6 Check AIS response to virtual vessels	---- <a href="#">Test Virtual Vessel</a>

Test Complete: ✔

Querying measurement data...  
Stopping AIS measurement...  
Stop measurement succeeded

Setting STB100 MMSI number to 999999999  
Input mode set to Direct  
Latitude set to 50.1015°  
Longitude set to -119.1164°  
Sending message 1 to selected transceiver...  
Message 1 sent  
Selected transceiver successfully received virtual vessel

[Go To Summary Page](#)

[Hide Activity Log](#) [Close](#)

The **Test Virtual Vessel** button will send a position report message to the selected transceiver to emulate a ship in the area.

The latitude and longitude included in the sent AIS position report are associated with the latitude and longitude of the transceiver under test. If a position report has not been received by the STB100 for the selected transceiver, the STB100 latitude and longitude located in the **Setup** tab will be used to spoof a ship's location.

The AIS measurement test in section 5 is run in **Direct Connection** mode.

**Note:** DSC Measurements are not available in the STB100.

## 6. "On Air" Performance Test:

The **"On-Air Performance Test"** requires the Transceiver to be connected with its antenna. The user must contact the Vessel Traffic Services (VTS) in the local area to verify transmission and reception of signals.

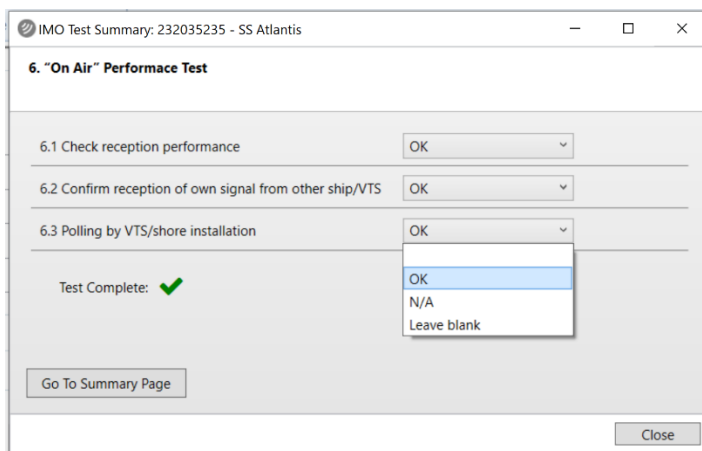
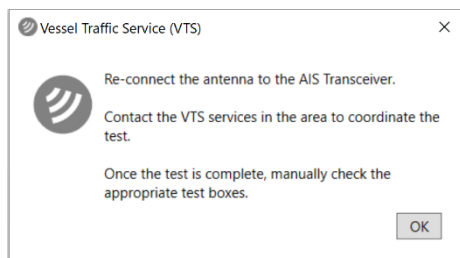

Once verified, enter the desired result for each test using the pull-down box.

When completed, click **Close**.

## Review:

Once the tests have been completed, go to the **Summary** page for reviewing the data prior to generating the *IMO Test Report*

The screenshot displays the STB100 Beacon Test Bench software interface. At the top, there are tabs for 'Beacon' and 'AIS'. Below these are sections for 'Measurements', 'Limits', 'User I/O', 'IMO Test', 'Individual Tests', and 'Setup'. The main area is divided into several panels:

- Station:** MMSI Number: 232035235, Manufacturer: McMurdo, Model: M5, Serial Number: 123456, Type: AIS Class A.
- Ship:** Name of Ship: SS Atlantis, Port of Registry: Spain, Gross Tonnage: 5000, Date Keel Laid: 2021-02-01, IMO Number: 654321.
- Test History:** A list of test results with columns for time and name (e.g., 2021-02-09 4:55 PM Name: IMO Test-3).
- IMO Test-3 Details:** A section with a 'Generate Report' button, containing a 'Measurement Summary' and a 'Test Steps Summary'.

The **Measurement Summary** section shows three messages:

- Message 3 (Direct):** Channel: AIS1, Frequency: 161.975204 MHz, Power: 41.5 dBm, Transmission Time: 24.8 ms.
- Message 5 (Direct):** Channel: AIS2, Frequency: 162.025197 MHz, Power: 41.4 dBm, Transmission Time: 51.5 ms.
- Message 3 (Antenna):** Channel: AIS2, Frequency: 162.025225 MHz, Power: 39.2 %, Transmission Time: 25 ms.

The **Test Steps Summary** section includes a checklist of installation details:

- 1. Installation Details (checked)
- 2. AIS programming - Static information (checked)
- 3. AIS programming - Dynamic information (checked)
- 4. AIS programming - voyage related information (checked)
- 5. Performance test using measuring instrument (checked)
- 6. "On air" performance test (checked)

The **1. Installation Details** section contains a list of items:

- 1.1 AIS transponder type: AIS Class A
- 1.2 Type approval certificate: Yes
- 1.3 Initial installation configuration report on board? Yes
- 1.4 Drawing approved? Yes
- 1.5 Main source of electrical power: AC
- 1.6 Emergency source of electrical power: Generator
- 1.7 Capacity to be verified if the AIS is connected to a battery: Yes
- 1.8 Pilot plug near pilots operating position? Yes
- 1.9 120 V AC provided near pilot plug? Yes

In the **Details - Measurement Summary** section, the user can review the RF measurement data and the decoded AIS data from each of the received messages.

In the **Details – Test Steps Summary** section, the user can review the data from each individual test.

Once the user is satisfied with the results, the *IMO Test Report* can be generated by pressing the **Generate Report** button.

## IMO TEST REPORTS AND DATA FILES

### Generate and Print IMO Test Report:

Use the buttons in the **Report** ribbon in the **IMO Test** screen to **Generate** or **Open** an IMO test report. A **Generate Report** button is available in the **Test Details** section in the **IMO Test** main screen if a test is selected.

You must have a suitable PDF viewer installed on your PC in order to view and print the IMO Test Report.

If **Enable image in test report** is selected in **Report Header Logo** section of the AIS **Setup** screen, the image will be placed in the top section of the generated IMO test report.

The *IMO Test Report* generated is based on standards according to IMO SN/Circ.227 and resolution MSC.74 (69), annex 3.

### Data Files and Folder Structure:

All measurement, test and transceiver data on the AIS side is saved to an **SQLite Version 3** database named **AISMeasurements.db**. The database is located in the selected folder in the **Files** section in the AIS **Setup** screen. The default location is 'C:\WST\STB100 – AIS'. Measurements can be viewed in the database via a third-party database viewing tool (example: 'DB Browser for SQLite').

*IMO Test Reports* will be saved at '..\'(Transceiver MMSI) – (Transceiver ship name)'. The *IMO Test Report* filename will be saved as '(Test date created)-(Test name).pdf' by default. Options to change the default test name, auto increment test name, and remove date from filename are located in the **Setup** screen under the **IMO Test** section.

## Measurement Table Schema:

```
TABLE Measurement (  
  measurement_id TEXT PRIMARY KEY,  
  test_id TEXT,  
  name TEXT,  
  date_time DATETIME,  
  delta_time_seconds FLOAT,  
  channel_number TEXT,  
  frequency TEXT,  
  power TEXT,  
  transmission_time_milliseconds FLOAT,  
  latitude FLOAT,  
  longitude FLOAT,  
  description TEXT, -- AIS beacon class comma separated list  
  full_hex TEXT,  
  input_mode TEXT,  
  reference_mode TEXT  
);
```

## SOFTWARE UPDATES

Software updates are available free of charge on the WS Technologies Inc. website: <https://www.wst.ca/stb100>

You are encouraged to keep your STB100 software up to date by downloading and installing the most current software revision.

## STB100 MODEL UPGRADING

All models can be remotely upgraded as desired. Please contact WS Technologies Inc. at [sales@wst.ca](mailto:sales@wst.ca) for upgrade costs and procedures.

## FREQUENTLY ASKED QUESTIONS

Also see FAQ on the website – [www.wst.ca](http://www.wst.ca)

### **My STB100 won't receive either 406 MHz or 121.5 MHz.**

Ensure that the proper Input mode is selected. If you are receiving a beacon self-test transmission through its antenna, then select **Antenna**. If you are connected directly to the beacon, then select **Direct Connection**. If you are connected via an external Screen Box, then select **Screen Box**.

### **When I activate the beacon in self-test mode, the measurements produce questionable results. Is there a problem with the beacon?**

In order to meet all of the Cospas-Sarsat requirements, a beacon is allowed a 15-minute warm-up period. When testing a beacon in self test, there is no warm-up period, hence some measurements may be somewhat skewed.

Also, in self-test, the 121.5 homing transmission may be different depending on the particular beacon. Some beacons transmit a short modulated signal, some beacons transmit a short unmodulated signal, and some beacons transmit no signal.

### **The beacon I want to measure has offset training frequencies on 121.5 and 243 MHz. How do I set up the Beacon Tester to receive these training frequencies?**

Measuring Training Frequencies is easy. Go to the Setup > VHF Training Frequencies and select the training frequencies you are using.

### **Why is my AIS Transceiver not responding to the STB100?**

The most common cause of the AIS transceiver being unresponsive to the STB100 is due to the incorrect MSSSI number entered. Double-check the STB100's MSSSI setting matches the transceiver.

### **How can I find out my AIS Transceiver's MSSSI (User ID) number?**

When setting up a transceiver, select the "Auto Fill" button in the Add Transceiver screen to have it automatically filled in. To check it manually, go into the Beacon Tester side, select AIS only, and wait for a burst. It will be displayed as the User ID number.

**I am testing an ELT with separate 121.5 and 406 output connectors. How do I get the results printed on one Test Report?**  
WST has a 121/406 high power, low loss combiner (p/n 850-CMB102) that can be used to combine both channels into one output. Contact [sales@wst.ca](mailto:sales@wst.ca) for information.

**Is the characteristic swept tone audio that I hear when the Beacon Tester receives a 121.5/243 MHz signal the actual demodulated audio from the beacon?**

No, the swept tone audio is just an audio file played when the tester has received a 121 MHz or 243 MHz signal.

**The audible sounds that occur when a signal is received are wonderful, but can I disable them?**

Under the Beacon tab, go to Setup > Misc and check the Off box adjacent to Measurement Detected Sound.

**Notes:**

# SPECIFICATIONS

406 MHz Measurements		Uncertainty
<b>First Generation Beacon (FGB)</b>		
Measures all Cospas-Sarsat Channels		-
Decodes all Cospas-Sarsat Protocols		-
15 HEX ID & Full HEX		-
Frequency (Ext Ref)		± 1.0 Hz
Frequency (Int Ref)		
Leaving factory		± 50 Hz
Long Term		± 1.0 ppm/yr
Frequency Stability (using Ext Reference)	Nominal Frequency	± 2.5 x 10 <sup>-11</sup>
	Short Term	
	Medium Term – Mean Slope	
	Medium Term - Residual	
Power		± 0.25 dB <sup>1</sup>
Power rise time		± 0.5 ms
Pre-burst level		± 1.0 dB
Pulse Repetition period		± 10 ms
Bit rate		± 0.1 bps
CW preamble time		± 0.8 ms
Total transmission time		± 0.8 ms
Rise time		± 10 µs
Fall time		± 10 µs
Phase deviation: positive		± 0.02 rad
Phase deviation: negative		± 0.02 rad
Modulation phase symmetry		± 0.005
<b>Second Generation Beacon (SGB)</b>		
Measures all Cospas-Sarsat Protocols		-
Decodes all Cospas-Sarsat Protocols		-
23 HEX ID and Full HEX		-
Power		± 0.25 dB
Power Rise/Fall Time		± 0.1 ms
Pre-Burst and Post-Burst Level		± 1.0 dB
Total Transmission Time		± 0.25 ms
Nominal Frequency (Ext Ref)		± 25 Hz
(Int Ref) Leaving Factory		± 25 Hz
(Int Ref) Long Term		± 1.0 ppm/yr
Frequency Stability		Coming Soon
Chip Rate Average		± 0.05 cps
Chip Rate Variation		± 0.05 cps <sup>2</sup>
I, Q Relative Offset		± 0.5 %
I, Q Peak to Peak Amplitude		± 0.5 %
Out of Band Emissions		± 0.1 %
Error Vector Magnitude (EVM)		± 1.0 %
<b>Graphic Measurements</b>		
-406 spectrum mask graphics data		-
-406 output power during burst graphic data		-
-406 phase modulation graphics data		-

<sup>1</sup>35-39 dBm

## SPECIFICATIONS (cont'd)

<b>121.5/243 MHz Measurements</b>	
Frequency (Ext Ref)	± 30 Hz
Frequency (Int Ref) Leaving factory Long Term	± 60 Hz ± 1.0 ppm/yr
Peak Power	± 1.0 dB
Sweep Direction	-
Audio Frequency - upper	± 30 Hz
Audio Frequency - lower	± 30 Hz
Audio Sweep Range	± 60 Hz
Modulation Index	± 5%
Sweep Rep Rate	± 0.1 Hz
Duty Cycle	± 2%
<b>AIS Measurements</b>	
Frequency (AIS1 & AIS2) (Ext Ref)	± 30 Hz
Frequency (Int Ref) Leaving factory Long Term	± 60 Hz ± 1.0 ppm/yr
Power	± 1.0 dB
AIS Messages Decode	-
Tx AIS Transceiver (Class A & B)	-

## SPECIFICATIONS (cont'd)

Miscellaneous Measurements	Range	Uncertainty
Vin @ DC PWR IN	1V to 30V	± 2%
Vout @ DC PWR OUT	1V to 30V	± 2%
Iout @ DC PWR OUT	5mA to 8A	± 2% (>100mA)
leakage current @ DC PWR OUT	200 nA to 40 µA	± 5%
Vdropout (Vin to Vout)	50 mV/A	-
Aux Analog Input (Aux ADCn)	0 – 12V	± 2%
Temperature (probe 1 and probe 2)	-60°C to +75°C	± 0.5 °C

### Interface Parameters

#### 50 Ω RF Input

Connector	BNC-f	
VSWR	1.20:1	
Dynamic Range:	Direct Connection	Screen Box Connection
406 MHz Burst	+20 dBm to +43 dBm	-13 dBm min
121.5 MHz/243 MHz	+ 5 dBm to +35 dBm	-16 dBm min
AIS	+20 dBm to + 43 dBm	+5 dBm min
Absolute Maximum Input Level (Burst)		+44 dBm
Absolute Maximum Input Level (Continuous)		+35 dBm

#### Antenna RF Input

RF Range	
406 MHz	>5 m
121.5 MHz/243 MHz	>5 m
AIS	>30m
Connector	SMA-m (RP)
Absolute Maximum Input Level	10 dBm

#### 10 MHz Input

Connector	BNC-f
VSWR	1.40:1
Input Level Range	-10 to +10 dBm

#### GPS ANT Input

Connector	SMA-f
Bias	+5V current limited

#### USER I/O Connector

Connector	D-subminiature, 26 pin, HD
Functions:	
-AUX I/O	-8 I/O lines, 5V TTL Tolerant
-AUX ADC	-8 analog inputs, 0V -12 V
-RELAY1	-Relay1 NC/NO 60V 2A
-RELAY2	-Relay2 NC/NO 60V 2A
-PPS Out	-GPS 1 PPS Output
-GPS Tx	-GPS Tx
-GPS Rx	-GPS Rx
-Ground	-Ground

#### PPS OUT

Connector	SMA-f
Level	Logic level

#### AC Power Input

Connector	IEC 320 Appliance Input
Voltage	85-264 VAC
Frequency	47-63 Hz

### Environmental and Mechanical

Operating Temperature Range	+10°C to +35°C
Storage Temperature Range	-20°C to +60°C
Temperature Probe type	RTD
Dimensions: w x l x h mm (inches)	210 (8.3) x 280 (11.1) x 64 (2.5)
Weight	2.73 kg (6.0 lbs)

## **REGULATORY INFORMATION**

### **CANADA**

This device complies with Industry Canada's licence-exempt RSSs. Operation is subject to the following two conditions:

- (1) This device may not cause interference; and
- (2) This device must accept any interference, including interference that may cause undesired operation of the device.

### **USA**

NOTE: This equipment has been tested and found to comply with the limits for a Class A digital device, pursuant to part 15 of the FCC Rules. These limits are designed to provide reasonable protection against harmful interference when the equipment is operated in a commercial environment. This equipment generates, uses, and can radiate radio frequency energy and, if not installed and used in accordance with the instruction manual, may cause harmful interference to radio communications. Operation of this equipment in a residential area is likely to cause harmful interference, in which case the user will be required to correct the interference at his own expense.

## EUROPEAN UNION

### DECLARATION OF CONFORMITY

Supplier Name: WS Technologies Inc.  
Supplier Address: #2 – 215 Neave Road  
Kelowna, B.C.  
Canada V1V 2L9

Declares under our sole responsibility that the following product

Product Name: Beacon Test Bench  
Model STB100

Conforms to the following normative European and International Standards

Normative Standards: EN 301 489-1 V1.9.2 (2011-09)  
EN 55022:2010  
EN 61000-4-2:2008  
EN 61000-4-3:2010  
EN 61000-4-6:2008-10  
EN 61000-4-11:2004

Following the provisions of the normative European Council Directive 2004/108/EC EMC Directive.

---

Product conformance to cited product specifications is based on sample (type) testing, evaluation, or assessment at Celltech Labs Inc. located in Kelowna, Canada.

---

**Supplementary Information:** This product was tested and complies with all the applicable requirements for the CE Mark.

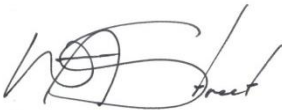

W. Street  
President  
WS Technologies Inc.  
#2 – 215 Neave Road  
Kelowna, BC  
Canada V1Y 5L9  
Phone: (250) 765-7583  
FAX: (250) 765-1652

## **WARRANTY INFORMATION**

WS Technologies Inc. (WST) warrants the products manufactured by WST to be free from defects in material and workmanship for one year from the date of shipment. Liability of WST under the foregoing warranty is limited to the replacement or repair, at the option of WST, of any products which show defective workmanship or materials within one year from the date of shipment, which replacement shall be made Exworks (EXW) WST's facility in Kelowna, BC, CANADA, upon proof satisfactory to WST of the defect claimed. Except for the foregoing warranty, WST makes no other warranty, express or implied, as to the merchantability or fitness for a particular purpose of products shipped or the performance thereof, and does not make any warranty to the purchaser's customers or agents.

## **CALIBRATION**

The STB100 has been designed to have a standard 2-year calibration cycle. The calibration date appears on the Calibration Certificate supplied with the Beacon Tester and the Calibration sticker applied to the top of the unit.

Before returning a unit for calibration, email [returns@wst.ca](mailto:returns@wst.ca) to obtain an RMA (Return Materials Authorization) number and shipping instructions. Once calibrated, a new Cal Due date label will be placed on the back of the unit, and a new Calibration Certificate will be issued.

## **RETURNS**

An RMA (Return Materials Authorization) number must be obtained by emailing [returns@wst.ca](mailto:returns@wst.ca). If the unit being returned is not covered under warranty, a minimum repair charge will apply. If damage is severe or the products have been tampered with, there may be additional charges.

## POWER CONVERSION CHART - dBm to Watts

<b>dBm</b>	<b>Watts</b>	<b>dBm</b>	<b>Watts</b>	<b>dBm</b>	<b>Watts</b>
-12	0.06 mW	8	6 mW	28	630 mW
-11	0.08 mW	9	8 mW	29	800 mW
-10	0.10 mW	10	10 mW	30	1.0 W
-9	0.13 mW	11	13 mW	31	1.3 W
-8	0.16 mW	12	16 mW	32	1.6 W
-7	0.20 mW	13	20 mW	33	2.0 W
-6	0.25 mW	14	25 mW	34	2.5 W
-5	0.32 mW	15	32 mW	35	3.2 W
-4	0.40 mW	16	40 mW	36	4.0 W
-3	0.50 mW	17	50 mW	37	5.0 W
-2	0.63 mW	18	63 mW	38	6.3 W
-1	0.8 mW	19	79 mW	39	8.0 W
0	1.0 mW	20	100 mW	40	10 W
1	1.3 mW	21	126 mW	41	13 W
2	1.6 mW	22	158 mW	42	16 W
3	2.0 mW	23	200 mW	43	20 W
4	2.5 mW	24	250 mW	44	25 W
5	3.2 mW	25	316 mW	45	32 W
6	4 mW	26	398 mW	46	40 W
7	5 mW	27	500 mW	47	50 W